

Component-Level Information Packet
for 08590-60102 & 08592-60068
Processor/Video Option E02 for HP 8593A

Copyright © 1991 Hewlett-Packard Company

All Rights Reserved.
Reproduction, adaptation, or translation
without prior written permission
is prohibited, except as allowed
under the copyright laws.

HP Document Part Number 08590-90123

Printed October 1989
Printed in USA

The information contained in this document is subject to change
without notice.



**HP Part Number 08590-60102
Processor/Video**

Reference Designation	HP Part Number	C	D	Qty	Description	Mfr Code	Mfr Part Number
A16	08590-60102	4		1	BD AY-PROC/VIDEO	28480	08590-60102
BT1	1420-0331	3		1	BATTERY 3.68V 1.75A-HR LITHIUM THIONYL		15-51-04-410-000
C1	0160-4835	7		1	CAPACITOR-FXD .1UF +-10% 50VDC CER	04222	SA115C104KAAH
C2	0160-4835	7		1	CAPACITOR-FXD .1UF +-10% 50VDC CER	04222	SA115C104KAAH
C3	0160-4835	7		1	CAPACITOR-FXD .1UF +-10% 50VDC CER	04222	SA115C104KAAH
C4	0160-4835	7		1	CAPACITOR-FXD .1UF +-10% 50VDC CER	04222	SA115C104KAAH
C5	0160-4835	7		1	CAPACITOR-FXD .1UF +-10% 50VDC CER	04222	SA115C104KAAH
C6	0160-4835	7		1	CAPACITOR-FXD .1UF +-10% 50VDC CER	04222	SA115C104KAAH
C10	0160-4835	7		1	CAPACITOR-FXD .1UF +-10% 50VDC CER	04222	SA115C104KAAH
C12	0160-4832	4		1	CAPACITOR-FXD .01UF +-10% 100VDC CER	04222	SA101C103KAAH
C13	0160-4832	4		1	CAPACITOR-FXD .01UF +-10% 100VDC CER	04222	SA101C103KAAH
C14	0160-4835	7		1	CAPACITOR-FXD .1UF +-10% 50VDC CER	04222	SA115C104KAAH
C15	0160-4835	7		1	CAPACITOR-FXD .1UF +-10% 50VDC CER	04222	SA115C104KAAH
C16	0160-4835	7		1	CAPACITOR-FXD .1UF +-10% 50VDC CER	04222	SA115C104KAAH
C17	0160-4832	4		1	CAPACITOR-FXD .01UF +-10% 100VDC CER	04222	SA101C103KAAH
C20	0160-4832	4		1	CAPACITOR-FXD .01UF +-10% 100VDC CER	04222	SA101C103KAAH
C22	0160-4832	4		1	CAPACITOR-FXD .01UF +-10% 100VDC CER	04222	SA101C103KAAH
C23	0180-3769	6		1	CAPACITOR-FXD 6.8UF+-10% 35VDC TA	56289	299D685X9035DB1
C24	0160-6588	1		1	CAPACITOR-FXD .033UF +-10% 100VDC CER	04222	SA301C333KAAH
C25	0160-5099	7		1	CAPACITOR-FXD 3300PF +-5% 100VDC CER 0+-	04222	SA301A332JAAH
C26	0160-4835	7		1	CAPACITOR-FXD .1UF +-10% 50VDC CER	04222	SA115C104KAAH
C27	0160-4832	4		1	CAPACITOR-FXD .01UF +-10% 100VDC CER	04222	SA101C103KAAH
C28	0160-4574	1		1	CAPACITOR-FXD 1000PF +-10% 100VDC CER	04222	SA101C102KAAH
C29	0160-4832	4		1	CAPACITOR-FXD .01UF +-10% 100VDC CER	04222	SA101C103KAAH
C30	0160-4832	4		1	CAPACITOR-FXD .01UF +-10% 100VDC CER	04222	SA101C103KAAH
C31	0160-4832	4		1	CAPACITOR-FXD .01UF +-10% 100VDC CER	04222	SA101C103KAAH
C32	0160-4832	4		1	CAPACITOR-FXD .01UF +-10% 100VDC CER	04222	SA101C103KAAH
C33	0160-4807	3		1	CAPACITOR-FXD 33PF +-5% 100VDC CER 0+-30	04222	SA102A330JAAH
C34	0160-4832	4		1	CAPACITOR-FXD .01UF +-10% 100VDC CER	04222	SA101C103KAAH
C35	0160-4832	4		1	CAPACITOR-FXD .01UF +-10% 100VDC CER	04222	SA101C103KAAH
C36	0160-4832	4		1	CAPACITOR-FXD .01UF +-10% 100VDC CER	04222	SA101C103KAAH
C37	0160-4832	4		1	CAPACITOR-FXD .01UF +-10% 100VDC CER	04222	SA101C103KAAH
C38	0160-4835	7		1	CAPACITOR-FXD .1UF +-10% 50VDC CER	04222	SA115C104KAAH
C39	0180-3769	6		1	CAPACITOR-FXD 6.8UF+-10% 35VDC TA	56289	299D685X9035DB1
C40	0180-3769	6		1	CAPACITOR-FXD 6.8UF+-10% 35VDC TA	56289	299D685X9035DB1
C41	0160-4832	4		1	CAPACITOR-FXD .01UF +-10% 100VDC CER	04222	SA101C103KAAH
C43	0160-4832	4		1	CAPACITOR-FXD .01UF +-10% 100VDC CER	04222	SA101C103KAAH
C44	0160-4835	7		1	CAPACITOR-FXD .1UF +-10% 50VDC CER	04222	SA115C104KAAH
C45	0160-4790	3		1	CAPACITOR-FXD 12PF +-5% 100VDC CER 0+-30	04222	SA102A120JAAH
C46	0160-4574	1		1	CAPACITOR-FXD 1000PF +-10% 100VDC CER	04222	SA101C102KAAH
C47	0160-4682	2		1	CAPACITOR-FXD 1000PF +-2.5% 160VDC POLYP		B33062-A1102-H
C48	0160-4832	4		1	CAPACITOR-FXD .01UF +-10% 100VDC CER	04222	SA101C103KAAH
C50	0160-4832	4		1	CAPACITOR-FXD .01UF +-10% 100VDC CER	04222	SA101C103KAAH
C51	0160-4832	4		1	CAPACITOR-FXD .01UF +-10% 100VDC CER	04222	SA101C103KAAH
C52	0160-4832	4		1	CAPACITOR-FXD .01UF +-10% 100VDC CER	04222	SA101C103KAAH
C54	0160-4832	4		1	CAPACITOR-FXD .01UF +-10% 100VDC CER	04222	SA101C103KAAH
C55	0160-4832	4		1	CAPACITOR-FXD .01UF +-10% 100VDC CER	04222	SA101C103KAAH
C56	0160-4832	4		1	CAPACITOR-FXD .01UF +-10% 100VDC CER	04222	SA101C103KAAH

*Indicates factory-selected value

HP Part Number 08590-60102
Processor/Video

Reference Designation	HP Part Number	C D	Qty	Description	Mfr Code	Mfr Part Number
C57	0180-3769	6	1	CAPACITOR-FXD 6.8UF+-10% 35VDC TA	56289	299D685X9035DB1
C58	0160-4832	4	1	CAPACITOR-FXD .01UF +-10% 100VDC CER	04222	SA101C103KAAH
C59	0160-4832	4	1	CAPACITOR-FXD .01UF +-10% 100VDC CER	04222	SA101C103KAAH
C60	0180-3769	6	1	CAPACITOR-FXD 6.8UF+-10% 35VDC TA	56289	299D685X9035DB1
C61	0180-3769	6	1	CAPACITOR-FXD 6.8UF+-10% 35VDC TA	56289	299D685X9035DB1
C62	0160-4832	4	1	CAPACITOR-FXD .01UF +-10% 100VDC CER	04222	SA101C103KAAH
C63	0160-4832	4	1	CAPACITOR-FXD .01UF +-10% 100VDC CER	04222	SA101C103KAAH
C64	0160-4832	4	1	CAPACITOR-FXD .01UF +-10% 100VDC CER	04222	SA101C103KAAH
C65	0160-4832	4	1	CAPACITOR-FXD .01UF +-10% 100VDC CER	04222	SA101C103KAAH
C66	0160-4832	4	1	CAPACITOR-FXD .01UF +-10% 100VDC CER	04222	SA101C103KAAH
C67	0160-4832	4	1	CAPACITOR-FXD .01UF +-10% 100VDC CER	04222	SA101C103KAAH
C101	0180-3769	6	1	CAPACITOR-FXD 6.8UF+-10% 35VDC TA	56289	299D685X9035DB1
C102	0160-4832	4	1	CAPACITOR-FXD .01UF +-10% 100VDC CER	04222	SA101C103KAAH
C103	0160-4832	4	1	CAPACITOR-FXD .01UF +-10% 100VDC CER	04222	SA101C103KAAH
C104	0160-4835	7	1	CAPACITOR-FXD .1UF +-10% 50VDC CER	04222	SA115C104KAAH
C105	0160-4832	4	1	CAPACITOR-FXD .01UF +-10% 100VDC CER	04222	SA101C103KAAH
C106	0180-3740	3	1	CAPACITOR-FXD .22F+80-20% 5VDC CARBON (D	S0545	FS0H224Z
C107	0160-4832	4	1	CAPACITOR-FXD .01UF +-10% 100VDC CER	04222	SA101C103KAAH
C108	0160-4835	7	1	CAPACITOR-FXD .1UF +-10% 50VDC CER	04222	SA115C104KAAH
C109	0160-4835	7	1	CAPACITOR-FXD .1UF +-10% 50VDC CER	04222	SA115C104KAAH
C111	0160-4832	4	1	CAPACITOR-FXD .01UF +-10% 100VDC CER	04222	SA101C103KAAH
C112	0160-4832	4	1	CAPACITOR-FXD .01UF +-10% 100VDC CER	04222	SA101C103KAAH
C113	0160-4832	4	1	CAPACITOR-FXD .01UF +-10% 100VDC CER	04222	SA101C103KAAH
C114	0160-4832	4	1	CAPACITOR-FXD .01UF +-10% 100VDC CER	04222	SA101C103KAAH
C201	0160-4802	8	1	CAPACITOR-FXD 82PF +-5% 100VDC CER 0+-30	04222	SA102A820JAAH
C202	0160-4789	0	1	CAPACITOR-FXD 15PF +-5% 100VDC CER 0+-30	04222	SA102A150JAAH
C203	0160-4832	4	1	CAPACITOR-FXD .01UF +-10% 100VDC CER	04222	SA101C103KAAH
C204	0160-4832	4	1	CAPACITOR-FXD .01UF +-10% 100VDC CER	04222	SA101C103KAAH
C205	0160-4801	7	1	CAPACITOR-FXD 100PF +-5% 100VDC CER 0+-3	04222	SA102A101JAAH
C206	0160-4832	4	1	CAPACITOR-FXD .01UF +-10% 100VDC CER	04222	SA101C103KAAH
C207	0160-4832	4	1	CAPACITOR-FXD .01UF +-10% 100VDC CER	04222	SA101C103KAAH
C208	0160-4805	1	1	CAPACITOR-FXD 47PF +-5% 100VDC CER 0+-30	04222	SA102A470JAAH
C209	0160-4832	4	1	CAPACITOR-FXD .01UF +-10% 100VDC CER	04222	SA101C103KAAH
C301	0160-4835	7	1	CAPACITOR-FXD .1UF +-10% 50VDC CER	04222	SA115C104KAAH
C302	0160-4832	4	1	CAPACITOR-FXD .01UF +-10% 100VDC CER	04222	SA101C103KAAH
C303	0160-4832	4	1	CAPACITOR-FXD .01UF +-10% 100VDC CER	04222	SA101C103KAAH
C304	0160-4832	4	1	CAPACITOR-FXD .01UF +-10% 100VDC CER	04222	SA101C103KAAH
C305	0160-4835	7	1	CAPACITOR-FXD .1UF +-10% 50VDC CER	04222	SA115C104KAAH
C306	0160-4835	7	1	CAPACITOR-FXD .1UF +-10% 50VDC CER	04222	SA115C104KAAH
C307	0160-4835	7	1	CAPACITOR-FXD .1UF +-10% 50VDC CER	04222	SA115C104KAAH
C308	0160-4832	4	1	CAPACITOR-FXD .01UF +-10% 100VDC CER	04222	SA101C103KAAH
C309	0160-4832	4	1	CAPACITOR-FXD .01UF +-10% 100VDC CER	04222	SA101C103KAAH
C310	0160-4832	4	1	CAPACITOR-FXD .01UF +-10% 100VDC CER	04222	SA101C103KAAH
C311	0160-4805	1	1	CAPACITOR-FXD 47PF +-5% 100VDC CER 0+-30	04222	SA102A470JAAH
C312	0160-4835	7	1	CAPACITOR-FXD .1UF +-10% 50VDC CER	04222	SA115C104KAAH
C313	0160-4832	4	1	CAPACITOR-FXD .01UF +-10% 100VDC CER	04222	SA101C103KAAH
C314	0160-4835	7	1	CAPACITOR-FXD .1UF +-10% 50VDC CER	04222	SA115C104KAAH

HP Part Number 08590-60102
Processor/Video

Reference Designation	HP Part Number	C D	Qty	Description	Mfr Code	Mfr Part Number
C315	0160-4835	7	1	CAPACITOR-FXD .1UF +-10% 50VDC CER	04222	SA115C104KAAH
C316	0160-4835	7	1	CAPACITOR-FXD .1UF +-10% 50VDC CER	04222	SA115C104KAAH
C317	0160-4835	7	1	CAPACITOR-FXD .1UF +-10% 50VDC CER	04222	SA115C104KAAH
C318	0180-0116	1	1	CAPACITOR-FXD 6.8UF+-10% 35VDC TA	56289	150D685X9035B2-DYS
C401	0160-4386	3	1	CAPACITOR-FXD 33PF +-5% 200VDC CER 0+-30		RPE121-105C0G330J200V
C402	0160-4386	3	1	CAPACITOR-FXD 33PF +-5% 200VDC CER 0+-30		RPE121-105C0G330J200V
C403	0160-4386	3	1	CAPACITOR-FXD 33PF +-5% 200VDC CER 0+-30		RPE121-105C0G330J200V
CR4	1901-0050	3	1	DIODE-SWITCHING 80V 200MA 2NS DO-35	9N171	1N4150
CR5	1901-0050	3	1	DIODE-SWITCHING 80V 200MA 2NS DO-35	9N171	1N4150
CR6	1901-0050	3	1	DIODE-SWITCHING 80V 200MA 2NS DO-35	9N171	1N4150
CR7	1901-0539	3	1	DIODE-SCHOTTKY SM SIG		
CR8	1901-1131	3	1	DIODE-SCHOTTKY SM SIG	28480	
CR101	1901-0050	3	1	DIODE-SWITCHING 80V 200MA 2NS DO-35	9N171	1N4150
CR102	1901-0050	3	1	DIODE-SWITCHING 80V 200MA 2NS DO-35	9N171	1N4150
CR103	1901-0050	3	1	DIODE-SWITCHING 80V 200MA 2NS DO-35	9N171	1N4150
CR104	1901-0050	3	1	DIODE-SWITCHING 80V 200MA 2NS DO-35	9N171	1N4150
CR105	1901-0050	3	1	DIODE-SWITCHING 80V 200MA 2NS DO-35	9N171	1N4150
CR106	1901-0050	3	1	DIODE-SWITCHING 80V 200MA 2NS DO-35	9N171	1N4150
CR107	1901-0050	3	1	DIODE-SWITCHING 80V 200MA 2NS DO-35	9N171	1N4150
CR108	1901-0050	3	1	DIODE-SWITCHING 80V 200MA 2NS DO-35	9N171	1N4150
CR109	1901-0050	3	1	DIODE-SWITCHING 80V 200MA 2NS DO-35	9N171	1N4150
CR110	1901-0734	0	1	DIODE-PWR RECT 1N5818 30V 1A	04713	1N5818
CR111	1901-0050	3	1	DIODE-SWITCHING 80V 200MA 2NS DO-35	9N171	1N4150
CR112	1901-0050	3	1	DIODE-SWITCHING 80V 200MA 2NS DO-35	9N171	1N4150
CR201	1901-0050	3	1	DIODE-SWITCHING 80V 200MA 2NS DO-35	9N171	1N4150
CR202	1901-0050	3	1	DIODE-SWITCHING 80V 200MA 2NS DO-35	9N171	1N4150
CR203	1901-0539	3	1	DIODE-SCHOTTKY SM SIG		
CR301	1901-0539	3	1	DIODE-SCHOTTKY SM SIG		
CR401	1901-0743	1	1	DIODE-PWR RECT 1N4004 400V 1A DO-41	71744	1N4004
CR402	1901-0743	1	1	DIODE-PWR RECT 1N4004 400V 1A DO-41	71744	1N4004
CR403	1901-0743	1	1	DIODE-PWR RECT 1N4004 400V 1A DO-41	71744	1N4004
DS1	1990-1270	8	1	LED RED AXL .5 MCD	2M627	LTZ-MR15
DS2	1990-1270	8	1	LED RED AXL .5 MCD	2M627	LTZ-MR15
DS3	1990-1270	8	1	LED RED AXL .5 MCD	2M627	LTZ-MR15
DS4	1990-1270	8	1	LED RED AXL .5 MCD	2M627	LTZ-MR15
DS5	1990-1270	8	1	LED RED AXL .5 MCD	2M627	LTZ-MR15
DS6	1990-1270	8	1	LED RED AXL .5 MCD	2M627	LTZ-MR15
DS7	1990-1270	8	1	LED RED AXL .5 MCD	2M627	LTZ-MR15
DS8	1990-1270	8	1	LED RED AXL .5 MCD	2M627	LTZ-MR15
DS9	1990-1270	8	1	LED RED AXL .5 MCD	2M627	LTZ-MR15
DS10	1990-1270	8	1	LED RED AXL .5 MCD	2M627	LTZ-MR15
DS11	1990-1270	8	1	LED RED AXL .5 MCD	2M627	LTZ-MR15
DS12	1990-1270	8	1	LED RED AXL .5 MCD	2M627	LTZ-MR15
DS13	1990-1270	8	1	LED RED AXL .5 MCD	2M627	LTZ-MR15
DS14	1990-1270	8	1	LED RED AXL .5 MCD	2M627	LTZ-MR15
DS15	1990-1270	8	1	LED RED AXL .5 MCD	2M627	LTZ-MR15
DS16	1990-1270	8	1	LED RED AXL .5 MCD	2M627	LTZ-MR15
DS101	1990-1270	8	1	LED RED AXL .5 MCD	2M627	LTZ-MR15

**Indicates factory-selected value*

HP Part Number 08590-60102
Processor/Video

Reference Designation	HP Part Number	C	D	Qty	Description	Mfr Code	Mfr Part Number
FB201	9100-1788	6		1	CORE-FERRITE CHOKE-WIDEBAND IMP:680	02114	VK200 20/4B
FB301	9100-1788	6		1	CORE-FERRITE CHOKE-WIDEBAND IMP:680	02114	VK200 20/4B
FB401	9100-1788	6		1	CORE-FERRITE CHOKE-WIDEBAND IMP:680	02114	VK200 20/4B
FB402	9100-1788	6		1	CORE-FERRITE CHOKE-WIDEBAND IMP:680	02114	VK200 20/4B
J1	1252-2907	6		1	CONN MODU 60 F24	18873	65781-102
J2	1252-1284	0		1	CONN-POST TYPE .100-PIN-SPCG 40-CONT	00779	746865-9
J3	1252-2152	3		1	CONN-POST TYPE .100-PIN-SPCG 3-CONT	18873	69167-103
J4	1252-1470	6		1	CONN-POST TYPE .100-PIN-SPCG 40-CONT	00779	103922-1
J5	1250-1846	6		1	CONNECTOR-RF BNC FEM PC 50-OHM	24931	28JR342-1
J6	1252-1327	2		1	CONN-RECT D-SUBMIN 9-CKT 9-CONT	00779	745781-6
J7	1250-1846	6		1	CONNECTOR-RF BNC FEM PC 50-OHM	24931	28JR342-1
J8	1252-2162	5		1	CONN-POST TYPE .100-PIN-SPCG 5-CONT	18873	78208-105
J9	1252-1882	4		1	CONN-POST TYPE .100-PIN-SPCG 3-CONT	18873	78208-103
J10	1252-1065	5		1	CONN-POST TYPE .100-PIN-SPCG 24-CONT	00779	746878-5
J11	1252-3156	9		1	HDR 3POS 2CONT	18873	79275-103
L1	9100-1631	8		1	INDUCTOR RF-CH-MLD 56UH +-5% .166D-INX.3	99800	1537-64
L201	9100-1631	8		1	INDUCTOR RF-CH-MLD 56UH +-5% .166D-INX.3	99800	1537-64
L301	9140-0736	6		1	INDUCTOR-FIXED L:200 UH MIN @ 0.35 ADC,1	56289	
MP2	1200-0567	1		1	SOCKET-IC 28-CONT DIP DIP-SLDR	09922	DILB28P-308T
MP6	1200-0607	0		1	SOCKET-IC 16-CONT DIP DIP-SLDR	09922	DILB16P-308T
MP100	1200-1274	9		1	SOCKET-IC 68-CONT SQUARE DIP-SLDR	00779	821574-1
MP102	1200-1426	3		1	SOCKET-PLCC 28-CONT	00779	821581-1
MP103	1400-1267	4		1	HOLDER-BAT .531-.656-DIA FOR AA CELLS	91833	91
MP104	0361-0026	6		1	RIVET-SEMITUB OVH .089DIA .125LG	12014	R-4008-1/8
MP105	5041-8959	7		2	INSULATOR-PROCESSOR	28480	5041-8959
MP106	0361-1310	3		1	RUT BL PLASTIC		D30-0125-07
Q3	1855-0420	2		1	TRANSISTOR J-FET 2N4391 N-CHAN D-MODE TO	17856	2N4391
Q4	1853-0007	7		1	TRANSISTOR PNP 2N3251 SI TO-18 PD=360MW	04713	2N3251
Q5	1855-0420	2		1	TRANSISTOR J-FET 2N4391 N-CHAN D-MODE TO	17856	2N4391
Q6	1855-0276	6		1	TRANSISTOR J-FET 2N4416A N-CHAN D-MODE T	04713	2N4416A
Q7	1855-0420	2		1	TRANSISTOR J-FET 2N4391 N-CHAN D-MODE TO	17856	2N4391
Q8	1855-0675	9		1	TRANSISTOR MOSFET N-CHAN E-MODE SI	04713	MPF6660
Q201	1854-0215	1		1	TRANSISTOR NPN SI TO-92 PD=350MW	04713	2N3904
Q301	1854-0215	1		1	TRANSISTOR NPN SI TO-92 PD=350MW	04713	2N3904
Q302	1854-0215	1		1	TRANSISTOR NPN SI TO-92 PD=350MW	04713	2N3904
Q303	1854-0215	1		1	TRANSISTOR NPN SI TO-92 PD=350MW	04713	2N3904
R5	0698-7260	7		1	RESISTOR 10K 1% .05W TF TC=0+-100	19701	5063J
R6	0698-7260	7		1	RESISTOR 10K 1% .05W TF TC=0+-100	19701	5063J
R8	0698-7231	2		1	RESISTOR 619 1% .05W TF TC=0+-100	19701	5063J
R9	0698-7212	9		1	RESISTOR 100 1% .05W TF TC=0+-100	19701	5063J
R10	0698-7236	7		1	RESISTOR 1K 1% .05W TF TC=0+-100	19701	5063J
R11	0698-7236	7		1	RESISTOR 1K 1% .05W TF TC=0+-100	19701	5063J
R19	0698-7260	7		1	RESISTOR 10K 1% .05W TF TC=0+-100	19701	5063J
R20	0698-7260	7		1	RESISTOR 10K 1% .05W TF TC=0+-100	19701	5063J
R21	0698-7260	7		1	RESISTOR 10K 1% .05W TF TC=0+-100	19701	5063J
R23	0698-7196	8		1	RESISTOR 21.5 1% .05W TF TC=0+-100	19701	5063J
R27	0698-7248	1		1	RESISTOR 3.16K 1% .05W TF TC=0+-100	19701	5063J

HP Part Number 08590-60102
Processor/Video

Reference Designation	HP Part Number	C	D	Qty	Description	Mfr Code	Mfr Part Number
R28	0698-7214	1		1	RESISTOR 121 1% .05W TF TC=0+-100	19701	5063J
R29	0698-7284	5		1	RESISTOR 100K 1% .05W TF TC=0+-100	19701	5023R
R30	0698-7277	6		1	RESISTOR 51.1K 1% .05W TF TC=0+-100	19701	5023R
R31	0698-7225	4		1	RESISTOR 348 1% .05W TF TC=0+-100	19701	5063J
R32	0698-7258	3		1	RESISTOR 8.25K 1% .05W TF TC=0+-100	19701	5063J
R33	0698-7255	0		1	RESISTOR 6.19K 1% .05W TF TC=0+-100	19701	5063J
R34	0698-7248	1		1	RESISTOR 3.16K 1% .05W TF TC=0+-100	19701	5063J
R35	0698-7220	9		1	RESISTOR 215 1% .05W TF TC=0+-100	19701	5063J
R36	0698-7212	9		1	RESISTOR 100 1% .05W TF TC=0+-100	19701	5063J
R37	0698-6320	8		1	RESISTOR 5K .1% .125W TF TC=0+-25	91637	CMF-55-1, T-9
R38	0698-7260	7		1	RESISTOR 10K 1% .05W TF TC=0+-100	19701	5063J
R39	0698-7247	0		1	RESISTOR 2.87K 1% .05W TF TC=0+-100	19701	5063J
R40	0698-7221	0		1	RESISTOR 237 1% .05W TF TC=0+-100	19701	5063J
R41	0698-6317	3		1	RESISTOR 500 .1% .125W TF TC=0+-25	91637	CMF-55-1, T-9
R42	0698-6317	3		1	RESISTOR 500 .1% .125W TF TC=0+-25	91637	CMF-55-1, T-9
R43	0698-6362	8		1	RESISTOR 1K .1% .125W TF TC=0+-25	19701	5033R
R44	0698-6317	3		1	RESISTOR 500 .1% .125W TF TC=0+-25	91637	CMF-55-1, T-9
R45	0698-7202	7		1	RESISTOR 38.3 1% .05W TF TC=0+-100	19701	5063J
R46	0698-7202	7		1	RESISTOR 38.3 1% .05W TF TC=0+-100	19701	5063J
R47	0698-7218	5		1	RESISTOR 178 1% .05W TF TC=0+-100	19701	5063J
R48	0698-7236	7		1	RESISTOR 1K 1% .05W TF TC=0+-100	19701	5063J
R49	0698-7250	5		1	RESISTOR 3.83K 1% .05W TF TC=0+-100	19701	5063J
R51	0698-7277	6		1	RESISTOR 51.1K 1% .05W TF TC=0+-100	19701	5023R
R52	0698-6362	8		1	RESISTOR 1K .1% .125W TF TC=0+-25	19701	5033R
R53	0698-6347	9		1	RESISTOR 1.5K .1% .125W TF TC=0+-25	19701	5033R
R54	0698-7284	5		1	RESISTOR 100K 1% .05W TF TC=0+-100	19701	5023R
R55	0698-7212	9		1	RESISTOR 100 1% .05W TF TC=0+-100	19701	5063J
R56	0698-7248	1		1	RESISTOR 3.16K 1% .05W TF TC=0+-100	19701	5063J
R57	0698-7248	1		1	RESISTOR 3.16K 1% .05W TF TC=0+-100	19701	5063J
R58	0698-7248	1		1	RESISTOR 3.16K 1% .05W TF TC=0+-100	19701	5063J
R60	0698-7260	7		1	RESISTOR 10K 1% .05W TF TC=0+-100	19701	5063J
R61	0698-7284	5		1	RESISTOR 100K 1% .05W TF TC=0+-100	19701	5023R
R62	0698-7277	6		1	RESISTOR 51.1K 1% .05W TF TC=0+-100	19701	5023R
R63	0698-7284	5		1	RESISTOR 100K 1% .05W TF TC=0+-100	19701	5023R
R64	0698-6317	3		1	RESISTOR 500 .1% .125W TF TC=0+-25	91637	CMF-55-1, T-9
R65	0698-6360	6		1	RESISTOR 10K .1% .125W TF TC=0+-25	19701	5033R
R66	0698-7205	0		1	RESISTOR 51.1 1% .05W TF TC=0+-100	19701	5063J
R67	0698-6631	4		1	RESISTOR 2.5K .1% .125W TF TC=0+-25	19701	5033R
R68	0698-6360	6		1	RESISTOR 10K .1% .125W TF TC=0+-25	19701	5033R
R69	0698-7205	0		1	RESISTOR 51.1 1% .05W TF TC=0+-100	19701	5063J
R70	0698-7260	7		1	RESISTOR 10K 1% .05W TF TC=0+-100	19701	5063J
R71	0698-7260	7		1	RESISTOR 10K 1% .05W TF TC=0+-100	19701	5063J
R72	0698-7221	0		1	RESISTOR 237 1% .05W TF TC=0+-100	19701	5063J
R78	0698-7260	7		1	RESISTOR 10K 1% .05W TF TC=0+-100	19701	5063J
R101	0698-7260	7		1	RESISTOR 10K 1% .05W TF TC=0+-100	19701	5063J
R102	0698-7260	7		1	RESISTOR 10K 1% .05W TF TC=0+-100	19701	5063J
R103	0698-7236	7		1	RESISTOR 1K 1% .05W TF TC=0+-100	19701	5063J
R105	0698-7245	8		1	RESISTOR 2.37K 1% .05W TF TC=0+-100	19701	5063J

*Indicates factory-selected value

HP Part Number 08590-60102
Processor/Video

Reference Designation	HP Part Number	C	D	Qty	Description	Mfr Code	Mfr Part Number
R106	0698-7260	7		1	RESISTOR 10K 1% .05W TF TC=0+-100	19701	5063J
R107	0698-7260	7		1	RESISTOR 10K 1% .05W TF TC=0+-100	19701	5063J
R108	0698-7260	7		1	RESISTOR 10K 1% .05W TF TC=0+-100	19701	5063J
R109	0698-7260	7		1	RESISTOR 10K 1% .05W TF TC=0+-100	19701	5063J
R110	0698-7260	7		1	RESISTOR 10K 1% .05W TF TC=0+-100	19701	5063J
R111	0698-7236	7		1	RESISTOR 1K 1% .05W TF TC=0+-100	19701	5063J
R201	0698-7188	8		1	RESISTOR 10 1% .05W TF TC=0+-100	19701	5063J
R202	0698-7212	9		1	RESISTOR 100 1% .05W TF TC=0+-100	19701	5063J
R203	0698-7253	8		1	RESISTOR 5.11K 1% .05W TF TC=0+-100	19701	5063J
R204	0698-7260	7		1	RESISTOR 10K 1% .05W TF TC=0+-100	19701	5063J
R205	0698-7243	6		1	RESISTOR 1.96K 1% .05W TF TC=0+-100	19701	5063J
R206	0698-7253	8		1	RESISTOR 5.11K 1% .05W TF TC=0+-100	19701	5063J
R207	0698-7260	7		1	RESISTOR 10K 1% .05W TF TC=0+-100	19701	5063J
R208	0698-7253	8		1	RESISTOR 5.11K 1% .05W TF TC=0+-100	19701	5063J
R209	0698-7277	6		1	RESISTOR 51.1K 1% .05W TF TC=0+-100	19701	5023R
R210	0698-7277	6		1	RESISTOR 51.1K 1% .05W TF TC=0+-100	19701	5023R
R301	0698-7243	6		1	RESISTOR 1.96K 1% .05W TF TC=0+-100	19701	5063J
R302	0698-7212	9		1	RESISTOR 100 1% .05W TF TC=0+-100	19701	5063J
R303	0698-7221	0		1	RESISTOR 237 1% .05W TF TC=0+-100	19701	5063J
R304	0698-7242	5		1	RESISTOR 1.78K 1% .05W TF TC=0+-100	19701	5063J
R305	0698-7224	3		1	RESISTOR 316 1% .05W TF TC=0+-100	19701	5063J
R306	0698-7253	8		1	RESISTOR 5.11K 1% .05W TF TC=0+-100	19701	5063J
R307	0698-7208	3		1	RESISTOR 68.1 1% .05W TF TC=0+-100	19701	5063J
R308	0698-7234	5		1	RESISTOR 825 1% .05W TF TC=0+-100	19701	5063J
R309	0698-7201	6		1	RESISTOR 34.8 1% .05W TF TC=0+-100	19701	5063J
R310	0757-0402	1		1	RESISTOR 110 1% .125W TF TC=0+-100	19701	SFR25H
R311	0698-7230	1		1	RESISTOR 562 1% .05W TF TC=0+-100	19701	5063J
R312	0698-7224	3		1	RESISTOR 316 1% .05W TF TC=0+-100	19701	5063J
R313	0698-7209	4		1	RESISTOR 75 1% .05W TF TC=0+-100	19701	5063J
R314	0698-7260	7		1	RESISTOR 10K 1% .05W TF TC=0+-100	19701	5063J
R315	0698-7245	8		1	RESISTOR 2.37K 1% .05W TF TC=0+-100	19701	5063J
R316	0698-7260	7		1	RESISTOR 10K 1% .05W TF TC=0+-100	19701	5063J
R317	0698-7260	7		1	RESISTOR 10K 1% .05W TF TC=0+-100	19701	5063J
R318	0698-7260	7		1	RESISTOR 10K 1% .05W TF TC=0+-100	19701	5063J
TP1	1251-5596	3		1	CONN-POST TYPE .100-PIN-SPCG 7-CONT	18873	68001-607
U2	1820-6218	5		1	IC TRANSCEIVER CMOS/74HC BUS OCTL	04713	MC74HC646N
U3	1820-6218	5		1	IC TRANSCEIVER CMOS/74HC BUS OCTL	04713	MC74HC646N
U4	1818-4017	3		1	IC CMOS 262144 (256K) STAT RAM 120-NS	S0562	TC55257APL-12
U5	1818-4017	3		1	IC CMOS 262144 (256K) STAT RAM 120-NS	S0562	TC55257APL-12
U6				1	PROGRAMMED EPROM, SEE SVC MNL	28480	
U7				1	PROGRAMMED EPROM, SEE SVC MNL	28480	
U9	1820-3298	5		1	IC GATE CMOS/74HC OR QUAD 2-INP	27014	MM74HC32N
U10	1820-3097	2		1	IC GATE CMOS/74HC AND QUAD 2-INP	27014	MM74HC08N
U11	1810-0286	4		1	NETWORK-RES 16-DIP 10.OK OHM X 15	11236	761-1-R10K
U12	1820-5844	1		1	IC-16-BIT MPU W/COUNTER, PLCC 8MHZ	04713	MC68HC000FN8
U13	1820-3173	5		1	IC FF CMOS/74HC J-K NEG-EDGE-TRIG PRESET	27014	MM74HC112N
U16	1820-3183	7		1	IC GATE CMOS/74HC NAND QUAD 2-INP	04713	MC74HC03N

HP Part Number 08590-60102
Processor/Video

Reference Designation	HP Part Number	C D	Qty	Description	Mfr Code	Mfr Part Number
U18	1820-2998	0	1	IC LCH CMOS/74HC TRANSPARENT OCTL	04713	MC74HC373N
U19	1820-3789	9	1	IC FF CMOS/74HC D-TYPE POS-EDGE-TRIG COM	27014	MM74HC574N
U20	1820-3789	9	1	IC FF CMOS/74HC D-TYPE POS-EDGE-TRIG COM	27014	MM74HC574N
U21	1818-4017	3	1	IC CMOS 262144 (256K) STAT RAM 120-NS	S0562	TC55257APL-12
U22	1818-4017	3	1	IC CMOS 262144 (256K) STAT RAM 120-NS	S0562	TC55257APL-12
U23			1	PROGRAMMED EPROM, SEE SVC MNL	28480	
U24			1	PROGRAMMED EPROM, SEE SVC MNL	28480	
U25	1251-4787	2	1	SHUNT-DIP 8 POSITION DUAL INLINE PKG	00779	435704-8
U26	1820-3080	3	1	IC GATE CMOS/74HC NAND DUAL 4-INP	04713	MC74HC20N
U32	1820-2922	0	1	IC GATE CMOS/74HC NAND QUAD 2-INP	04713	MC74HC00N
U33	1858-0077	1	1	TRANSISTOR ARRAY 14-PIN PLSTC TO-116	04713	MPQ2222P
U34	1810-0037	3	1	NETWORK-RES 16-DIP 1.0K OHM X 8	11236	761-3-R1K
U35	1826-0759	9	1	IC COMPARATOR GP QUAD 14-DIP-C PKG	27014	LM339J
U36	1820-3205	4	1	IC CNTR CMOS/74HC BIN UP/DOWN SYNCHRO PO	27014	MM74HC193N
U37	1820-3081	4	1	IC FF CMOS/74HC D-TYPE POS-EDGE-TRIG PRE	04713	MC74HC74N
U38	1810-0206	8	1	NETWORK-RES 8-SIP 10.0K OHM X 7	11236	750-81
U39	1820-2922	0	1	IC GATE CMOS/74HC NAND QUAD 2-INP	04713	MC74HC00N
U40	1820-5108	0	1	IC-PROGRAMMABLE INTERVAL TIMER 8MHZ CMOS	34649	N82C54
U41	1820-3298	5	1	IC GATE CMOS/74HC OR QUAD 2-INP	27014	MM74HC32N
U42	1820-3298	5	1	IC GATE CMOS/74HC OR QUAD 2-INP	27014	MM74HC32N
U44	1858-0077	1	1	TRANSISTOR ARRAY 14-PIN PLSTC TO-116	04713	MPQ2222P
U45	1826-1045	8	1	IC OP AMP H-SLEW-RATE 8-DIP-C PKG	34371	HA7-2515-5
U46	1826-1178	8	1	SAMPLE AND HOLD 14 -CERDIP	34371	HA1-5320-5
U47	1826-1522	6	1	A/D 12-DGT 28-CERDIP HYB	24355	AD574AJ (SELECTED)
U48	1810-0286	4	1	NETWORK-RES 16-DIP 10.0K OHM X 15	11236	761-1-R10K
U49	1820-3789	9	1	IC FF CMOS/74HC D-TYPE POS-EDGE-TRIG COM	27014	MM74HC574N
U52	1820-3079	0	1	IC DCDR CMOS/74HC 3-TO-8-LINE	04713	MC74HC138N
U53	1810-0286	4	1	NETWORK-RES 16-DIP 10.0K OHM X 15	11236	761-1-R10K
U54	1820-3297	4	1	IC DRVR CMOS/74HC BUS OCTL	04713	MC74HC244N
U56	1820-4675	4	1	IC ENCDR CMOS/74HC PRIORITY 8-TO-3-LINE	01295	SN74HC148N
U57	1820-3449	8	1	IC-PARALLEL INTERFACE/TIMER/8MHZ/MC68000	04713	MC68230L8
U58	1810-0205	7	1	NETWORK-RES 8-SIP 4.7K OHM X 7	11236	750-81
U60	1810-0203	5	1	NETWORK-RES 8-SIP 470.0 OHM X 7	11236	750-81
U61	1826-1939	9	1	IC OP AMP WB 8-TO-99 PKG	34371	HA2-5160-5
U62	1858-0032	8	1	TRANSISTOR ARRAY 14-PIN PLSTC DIP	27014	LM3146
U63	1858-0077	1	1	TRANSISTOR ARRAY 14-PIN PLSTC TO-116	04713	MPQ2222P
U64	1826-0609	8	1	ANALOG MULTIPLEXER 8 CHNL 16 -CERDIP	06665	MUX-08FQ
U65	1820-3789	9	1	IC FF CMOS/74HC D-TYPE POS-EDGE-TRIG COM	27014	MM74HC574N
U66	1820-3789	9	1	IC FF CMOS/74HC D-TYPE POS-EDGE-TRIG COM	27014	MM74HC574N
U68	1820-3297	4	1	IC DRVR CMOS/74HC BUS OCTL	04713	MC74HC244N
U71	1820-3081	4	1	IC FF CMOS/74HC D-TYPE POS-EDGE-TRIG PRE	04713	MC74HC74N
U72	1820-3185	9	1	IC SCHMITT-TRIG CMOS/74HC INV HEX	27014	MM74HC14N
U101	08590-80093	4	1	PAL PROGRAMMED	28480	08590-80093
U102	1820-3174	6	1	IC SCHMITT-TRIG CMOS/74HC NAND QUAD 2-IN	04713	MC74HC132N
U103	1820-5497	0	1	IC-NONVOLATILE MEMORY CONTROLLER		DS1210
U104	1826-1858	1	1	IC 1259 P BATMG		DS1259N
U105	1820-5497	0	1	IC-NONVOLATILE MEMORY CONTROLLER		DS1210
U106	1820-5384	4	1	IC-INTERFACE CMOS CLOCK		RTC-72421B

**Indicates factory-selected value*

HP Part Number 08590-60102
Processor/Video

Reference Designation	HP Part Number	C D	Qty	Description	Mfr Code	Mfr Part Number
U107	1810-0280	8	1	NETWORK-RES 10-SIP 10.0K OHM X 9	91637	MSP10A01
U108	1820-3789	9	1	IC FF CMOS/74HC D-TYPE POS-EDGE-TRIG COM	27014	MM74HC574N
U109	1810-0273	9	1	NETWORK-RES 10-SIP 470.0 OHM X 9	91637	MSP10A01
U110	1810-0280	8	1	NETWORK-RES 10-SIP 10.0K OHM X 9	91637	MSP10A01
U111	1820-3297	4	1	IC DRVR CMOS/74HC BUS OCTL	04713	MC74HC244N
U113	1820-3183	7	1	IC GATE CMOS/74HC NAND QUAD 2-INP	04713	MC74HC03N
U114	08590-80094	5	1	PAL PROGRAMMED	28480	08590-80094
U115	08590-80095	6	1	PAL PROGRAMMED	28480	08590-80095
U116	1820-3298	5	1	IC GATE CMOS/74HC OR QUAD 2-INP	27014	MM74HC32N
U117	1813-0129	0	1	CLOCK-OSCILLATOR-XTAL 14.7456-MHZ 0.01%	00815	HS-100(14.7456MHZ)
U118	1820-3537	5	1	IC FF CMOS/74HCT D-TYPE POS-EDGE-TRIG PR	18324	74HCT74N
U201	1826-0609	8	1	ANALOG MULTIPLEXER 8 CHNL 16 -CERDIP	06665	MUX-08FQ
U202	1826-1220	1	1	IC OP AMP WB 8-DIP-C PKG	34371	HA7-2525-5
U301	1820-6351	7	1	IC-CRT CONTROLLER 68-PLCC 8MHZ	S4013	HD63484CP8
U302	1820-2656	7	1	IC GATE TTL ALS NAND QUAD 2-INP	01295	SN74ALS00AN
U303	1820-2102	8	1	IC LCH TTL LS D-TYPE OCTL	01295	SN74LS373N
U304	1820-2102	8	1	IC LCH TTL LS D-TYPE OCTL	01295	SN74LS373N
U305	1818-4017	3	1	IC CMOS 262144 (256K) STAT RAM 120-NS	S0562	TC55257APL-12
U306	1818-4017	3	1	IC CMOS 262144 (256K) STAT RAM 120-NS	S0562	TC55257APL-12
U307	1813-0245	1	1	CLOCK-OSCILLATOR-XTAL 25.0-MHZ 0.05%		F1100HA-25MHZ .05%
U308	08590-80096	7	1	PAL-PROGRAMMED	28480	08590-80096
U309	1820-1922	8	1	IC SHF-RGTR TTL LS PRL-IN SERIAL-OUT 8-B	01295	SN74LS166AN
U310	1820-1922	8	1	IC SHF-RGTR TTL LS PRL-IN SERIAL-OUT 8-B	01295	SN74LS166AN
U311	1820-0535	7	1	IC-INTERFACE DRVR BCD AND DUAL	01295	SN75451BP
U312	1820-0535	7	1	IC-INTERFACE DRVR BCD AND DUAL	01295	SN75451BP
U401	1810-0301	4	1	NETWORK-RES 16-DIP 51.0 OHM X 8	11236	761-3-R51
U402	1810-0301	4	1	NETWORK-RES 16-DIP 51.0 OHM X 8	11236	761-3-R51
U403	1810-0301	4	1	NETWORK-RES 16-DIP 51.0 OHM X 8	11236	761-3-R51
U404	1810-0301	4	1	NETWORK-RES 16-DIP 51.0 OHM X 8	11236	761-3-R51
U405	1810-0301	4	1	NETWORK-RES 16-DIP 51.0 OHM X 8	11236	761-3-R51
U406	1810-0301	4	1	NETWORK-RES 16-DIP 51.0 OHM X 8	11236	761-3-R51
VR1	1902-0952	6	1	DIODE-ZNR 5.6V 5% DO-35 PD=.4W TC=+.046%	04713	
VR301	1902-0949	1	1	DIODE-ZNR 4.3V 5% DO-35 PD=.4W TC=+.017%	04713	
VR302	1902-0949	1	1	DIODE-ZNR 4.3V 5% DO-35 PD=.4W TC=+.017%	04713	
W102	8159-0005	0	1	RESISTOR-ZERO OHMS 22 AWG LEAD DIA	55210	L-2007-1
W103	8159-0005	0	1	RESISTOR-ZERO OHMS 22 AWG LEAD DIA	55210	L-2007-1
W104	8159-0005	0	1	RESISTOR-ZERO OHMS 22 AWG LEAD DIA	55210	L-2007-1

HP Part Number 08592-60068
Processor/Video

Reference Designation	HP Part Number	C D	Qty	Description	Mfr Code	Mfr Part Number
BT1	1420-0331	3	1	BATTERY 3.68V 1.75A-HR LITHIUM THIONYL	10183	15-51-04-410-000
C1	0160-4835	7	1	CAP-FXD 0.1uF 50 V	02010	SA115C104KAAH
C2	0160-4835	7	1	CAP-FXD 0.1uF 50 V	02010	SA115C104KAAH
C3	0160-4835	7	1	CAP-FXD 0.1uF 50 V	02010	SA115C104KAAH
C4	0160-4835	7	1	CAP-FXD 0.1uF 50 V	02010	SA115C104KAAH
C5	0160-4835	7	1	CAP-FXD 0.1uF 50 V	02010	SA115C104KAAH
C6	0160-4835	7	1	CAP-FXD 0.1uF 50 V	02010	SA115C104KAAH
C10	0160-4835	7	1	CAP-FXD 0.1uF 50 V	02010	SA115C104KAAH
C12	0160-4832	4	1	CAP-FXD 0.01uF 100 V	02010	SA101C103KAAH
C13	0160-4832	4	1	CAP-FXD 0.01uF 100 V	02010	SA101C103KAAH
C14	0160-4835	7	1	CAP-FXD 0.1uF 50 V	02010	SA115C104KAAH
C15	0160-4835	7	1	CAP-FXD 0.1uF 50 V	02010	SA115C104KAAH
C16	0160-4835	7	1	CAP-FXD 0.1uF 50 V	02010	SA115C104KAAH
C17	0160-4832	4	1	CAP-FXD 0.01uF 100 V	02010	SA101C103KAAH
C20	0160-4832	4	1	CAP-FXD 0.01uF 100 V	02010	SA101C103KAAH
C22	0160-4832	4	1	CAP-FXD 0.01uF 100 V	02010	SA101C103KAAH
C23	0180-3769	6	1	CAP-FXD 6.8uF 35 V TA	04200	299D685X9035DB1
C24	0160-6588	1	1	CAP-FXD 0.033uF 100 V	02010	SA301C333KAAH
C25	0160-5099	7	1	CAP-FXD 3300pF +-5% 100 V CER COG	02010	SA301A332JAAH
C26	0160-4835	7	1	CAP-FXD 0.1uF 50 V	02010	SA115C104KAAH
C27	0160-4832	4	1	CAP-FXD 0.01uF 100 V	02010	SA101C103KAAH
C28	0160-4574	1	1	CAP-FXD 1000pF 100 V	02010	SA101C102KAAH
C29	0160-4832	4	1	CAP-FXD 0.01uF 100 V	02010	SA101C103KAAH
C30	0160-4832	4	1	CAP-FXD 0.01uF 100 V	02010	SA101C103KAAH
C31	0160-4832	4	1	CAP-FXD 0.01uF 100 V	02010	SA101C103KAAH
C32	0160-4832	4	1	CAP-FXD 0.01uF 100 V	02010	SA101C103KAAH
C33	0160-4807	3	1	CAP-FXD 33pF +-5% 100 V CER COG	02010	SA102A330JAAH
C34	0160-4832	4	1	CAP-FXD 0.01uF 100 V	02010	SA101C103KAAH
C35	0160-4832	4	1	CAP-FXD 0.01uF 100 V	02010	SA101C103KAAH
C36	0160-4832	4	1	CAP-FXD 0.01uF 100 V	02010	SA101C103KAAH
C37	0160-4832	4	1	CAP-FXD 0.01uF 100 V	02010	SA101C103KAAH
C38	0160-4835	7	1	CAP-FXD 0.1uF 50 V	02010	SA115C104KAAH
C39	0180-3769	6	1	CAP-FXD 6.8uF 35 V TA	04200	299D685X9035DB1
C40	0180-3769	6	1	CAP-FXD 6.8uF 35 V TA	04200	299D685X9035DB1
C41	0160-4832	4	1	CAP-FXD 0.01uF 100 V	02010	SA101C103KAAH
C43	0160-4832	4	1	CAP-FXD 0.01uF 100 V	02010	SA101C103KAAH
C44	0160-4835	7	1	CAP-FXD 0.1uF 50 V	02010	SA115C104KAAH
C45	0160-4790	3	1	CAP-FXD 12pF +-5% 100 V CER COG	02010	SA102A120JAAH
C46	0160-4574	1	1	CAP-FXD 1000pF 100 V	02010	SA101C102KAAH
C47	0160-4682	2	1	CAP-FXD 1000pF 160 V POLYP-FL	03441	
C48	0160-4832	4	1	CAP-FXD 0.01uF 100 V	02010	SA101C103KAAH
C50	0160-4832	4	1	CAP-FXD 0.01uF 100 V	02010	SA101C103KAAH
C51	0160-4832	4	1	CAP-FXD 0.01uF 100 V	02010	SA101C103KAAH
C52	0160-4832	4	1	CAP-FXD 0.01uF 100 V	02010	SA101C103KAAH
C54	0160-4832	4	1	CAP-FXD 0.01uF 100 V	02010	SA101C103KAAH
C55	0160-4832	4	1	CAP-FXD 0.01uF 100 V	02010	SA101C103KAAH
C56	0160-4832	4	1	CAP-FXD 0.01uF 100 V	02010	SA101C103KAAH
C57	0180-3769	6	1	CAP-FXD 6.8uF 35 V TA	04200	299D685X9035DB1

*Indicates factory-selected value

HP Part Number 08592-60068
Processor/Video

Reference Designation	HP Part Number	C D	Qty	Description	Mfr Code	Mfr Part Number
C58	0160-4832	4	1	CAP-FXD 0.01uF 100 V	02010	SA101C103KAAH
C59	0160-4832	4	1	CAP-FXD 0.01uF 100 V	02010	SA101C103KAAH
C60	0180-3769	6	1	CAP-FXD 6.8uF 35 V TA	04200	299D685X9035DB1
C61	0180-3769	6	1	CAP-FXD 6.8uF 35 V TA	04200	299D685X9035DB1
C62	0160-4832	4	1	CAP-FXD 0.01uF 100 V	02010	SA101C103KAAH
C63	0160-4832	4	1	CAP-FXD 0.01uF 100 V	02010	SA101C103KAAH
C64	0160-4832	4	1	CAP-FXD 0.01uF 100 V	02010	SA101C103KAAH
C65	0160-4832	4	1	CAP-FXD 0.01uF 100 V	02010	SA101C103KAAH
C66	0160-4832	4	1	CAP-FXD 0.01uF 100 V	02010	SA101C103KAAH
C67	0160-4832	4	1	CAP-FXD 0.01uF 100 V	02010	SA101C103KAAH
C101	0180-3769	6	1	CAP-FXD 6.8uF 35 V TA	04200	299D685X9035DB1
C102	0160-4832	4	1	CAP-FXD 0.01uF 100 V	02010	SA101C103KAAH
C103	0160-4832	4	1	CAP-FXD 0.01uF 100 V	02010	SA101C103KAAH
C104	0160-4835	7	1	CAP-FXD 0.1uF 50 V	02010	SA115C104KAAH
C105	0160-4832	4	1	CAP-FXD 0.01uF 100 V	02010	SA101C103KAAH
C106	0180-3740	3	1	CAP-FXD 0.22F 5 V CARB	00039	FS0H224Z
C107	0160-4832	4	1	CAP-FXD 0.01uF 100 V	02010	SA101C103KAAH
C108	0160-4835	7	1	CAP-FXD 0.1uF 50 V	02010	SA115C104KAAH
C109	0160-4835	7	1	CAP-FXD 0.1uF 50 V	02010	SA115C104KAAH
C111	0160-4832	4	1	CAP-FXD 0.01uF 100 V	02010	SA101C103KAAH
C112	0160-4832	4	1	CAP-FXD 0.01uF 100 V	02010	SA101C103KAAH
C113	0160-4832	4	1	CAP-FXD 0.01uF 100 V	02010	SA101C103KAAH
C114	0160-4832	4	1	CAP-FXD 0.01uF 100 V	02010	SA101C103KAAH
C201	0160-4802	8	1	CAP-FXD 82pF +-5% 100 V CER COG	02010	SA102A820JAAH
C202	0160-4789	0	1	CAP-FXD 15pF +-5% 100 V CER COG	02010	SA102A150JAAH
C203	0160-4832	4	1	CAP-FXD 0.01uF 100 V	02010	SA101C103KAAH
C204	0160-4832	4	1	CAP-FXD 0.01uF 100 V	02010	SA101C103KAAH
C205	0160-4801	7	1	CAP-FXD 100pF +-5% 100 V CER COG	02010	SA102A101JAAH
C206	0160-4832	4	1	CAP-FXD 0.01uF 100 V	02010	SA101C103KAAH
C207	0160-4832	4	1	CAP-FXD 0.01uF 100 V	02010	SA101C103KAAH
C208	0160-4805	1	1	CAP-FXD 47pF +-5% 100 V CER COG	02010	SA102A470JAAH
C209	0160-4832	4	1	CAP-FXD 0.01uF 100 V	02010	SA101C103KAAH
C301	0160-4835	7	1	CAP-FXD 0.1uF 50 V	02010	SA115C104KAAH
C302	0160-4832	4	1	CAP-FXD 0.01uF 100 V	02010	SA101C103KAAH
C303	0160-4832	4	1	CAP-FXD 0.01uF 100 V	02010	SA101C103KAAH
C304	0160-4832	4	1	CAP-FXD 0.01uF 100 V	02010	SA101C103KAAH
C305	0160-4835	7	1	CAP-FXD 0.1uF 50 V	02010	SA115C104KAAH
C306	0160-4835	7	1	CAP-FXD 0.1uF 50 V	02010	SA115C104KAAH
C307	0160-4835	7	1	CAP-FXD 0.1uF 50 V	02010	SA115C104KAAH
C308	0160-4832	4	1	CAP-FXD 0.01uF 100 V	02010	SA101C103KAAH
C309	0160-4832	4	1	CAP-FXD 0.01uF 100 V	02010	SA101C103KAAH
C310	0160-4832	4	1	CAP-FXD 0.01uF 100 V	02010	SA101C103KAAH
C311	0160-4805	1	1	CAP-FXD 47pF +-5% 100 V CER COG	02010	SA102A470JAAH
C312	0160-4835	7	1	CAP-FXD 0.1uF 50 V	02010	SA115C104KAAH
C313	0160-4832	4	1	CAP-FXD 0.01uF 100 V	02010	SA101C103KAAH
C314	0160-4835	7	1	CAP-FXD 0.1uF 50 V	02010	SA115C104KAAH
C315	0160-4835	7	1	CAP-FXD 0.1uF 50 V	02010	SA115C104KAAH

HP Part Number 08592-60068
Processor/Video

Reference Designation	HP Part Number	C	D	Qty	Description	Mfr Code	Mfr Part Number
C316	0160-4835	7		1	CAP-FXD 0.1uF 50 V	02010	SA115C104KAAH
C317	0160-4835	7		1	CAP-FXD 0.1uF 50 V	02010	SA115C104KAAH
C318	0180-4132	9		1	CAP-FXD 6.8uF 35 V TA	04200	173D685X9035X
C401	0160-4386	3		1	CAP-FXD 33pF 200 V	02010	SR152A330JAA
C402	0160-4386	3		1	CAP-FXD 33pF 200 V	02010	SR152A330JAA
C403	0160-4386	3		1	CAP-FXD 33pF 200 V	02010	SR152A330JAA
CR4	1901-0050	3		1	DIODE-SWITCHING 80V 200MA 2NS DO-35	03334	BAV10 SELECTED
CR5	1901-0050	3		1	DIODE-SWITCHING 80V 200MA 2NS DO-35	03334	BAV10 SELECTED
CR6	1901-0050	3		1	DIODE-SWITCHING 80V 200MA 2NS DO-35	03334	BAV10 SELECTED
CR7	1901-0539	3		1	DIODE-SCHOTTKY SM SIG	02062	
CR8	1901-1131	3		1	DIODE-SCHOTTKY SM SIG	02062	5082-2810
CR101	1901-0050	3		1	DIODE-SWITCHING 80V 200MA 2NS DO-35	03334	BAV10 SELECTED
CR102	1901-0050	3		1	DIODE-SWITCHING 80V 200MA 2NS DO-35	03334	BAV10 SELECTED
CR103	1901-0050	3		1	DIODE-SWITCHING 80V 200MA 2NS DO-35	03334	BAV10 SELECTED
CR104	1901-0050	3		1	DIODE-SWITCHING 80V 200MA 2NS DO-35	03334	BAV10 SELECTED
CR105	1901-0050	3		1	DIODE-SWITCHING 80V 200MA 2NS DO-35	03334	BAV10 SELECTED
CR106	1901-0050	3		1	DIODE-SWITCHING 80V 200MA 2NS DO-35	03334	BAV10 SELECTED
CR107	1901-0050	3		1	DIODE-SWITCHING 80V 200MA 2NS DO-35	03334	BAV10 SELECTED
CR108	1901-0050	3		1	DIODE-SWITCHING 80V 200MA 2NS DO-35	03334	BAV10 SELECTED
CR109	1901-0050	3		1	DIODE-SWITCHING 80V 200MA 2NS DO-35	03334	BAV10 SELECTED
CR110	1901-0734	0		1	DIODE-PWR RECT 1N5818 30V 1A	02037	1N5818
CR111	1901-0050	3		1	DIODE-SWITCHING 80V 200MA 2NS DO-35	03334	BAV10 SELECTED
CR112	1901-0050	3		1	DIODE-SWITCHING 80V 200MA 2NS DO-35	03334	BAV10 SELECTED
CR201	1901-0050	3		1	DIODE-SWITCHING 80V 200MA 2NS DO-35	03334	BAV10 SELECTED
CR202	1901-0050	3		1	DIODE-SWITCHING 80V 200MA 2NS DO-35	03334	BAV10 SELECTED
CR203	1901-0539	3		1	DIODE-SCHOTTKY SM SIG	02062	
CR301	1901-0539	3		1	DIODE-SCHOTTKY SM SIG	02062	
CR401	1901-0743	1		1	DIODE-PWR RECT 1N4004 400V 1A DO-41	04504	1N4004
CR402	1901-0743	1		1	DIODE-PWR RECT 1N4004 400V 1A DO-41	04504	1N4004
CR403	1901-0743	1		1	DIODE-PWR RECT 1N4004 400V 1A DO-41	04504	1N4004
DS1	1990-1270	8		1	LED RED AXL .5 MCD	00746	LTZ-MR15
DS2	1990-1270	8		1	LED RED AXL .5 MCD	00746	LTZ-MR15
DS3	1990-1270	8		1	LED RED AXL .5 MCD	00746	LTZ-MR15
DS4	1990-1270	8		1	LED RED AXL .5 MCD	00746	LTZ-MR15
DS5	1990-1270	8		1	LED RED AXL .5 MCD	00746	LTZ-MR15
DS6	1990-1270	8		1	LED RED AXL .5 MCD	00746	LTZ-MR15
DS7	1990-1270	8		1	LED RED AXL .5 MCD	00746	LTZ-MR15
DS8	1990-1270	8		1	LED RED AXL .5 MCD	00746	LTZ-MR15
DS9	1990-1270	8		1	LED RED AXL .5 MCD	00746	LTZ-MR15
DS10	1990-1270	8		1	LED RED AXL .5 MCD	00746	LTZ-MR15
DS11	1990-1270	8		1	LED RED AXL .5 MCD	00746	LTZ-MR15
DS12	1990-1270	8		1	LED RED AXL .5 MCD	00746	LTZ-MR15
DS13	1990-1270	8		1	LED RED AXL .5 MCD	00746	LTZ-MR15
DS14	1990-1270	8		1	LED RED AXL .5 MCD	00746	LTZ-MR15
DS15	1990-1270	8		1	LED RED AXL .5 MCD	00746	LTZ-MR15
DS16	1990-1270	8		1	LED RED AXL .5 MCD	00746	LTZ-MR15
DS101	1990-1270	8		1	LED RED AXL .5 MCD	00746	LTZ-MR15
FB201	9100-1788	6		1	CORE-FERRITE CHOKE-WIDEBAND IMP:680 OHM	01887	VK200 20/48

**Indicates factory-selected value*

HP Part Number 08592-60068
Processor/Video

Reference Designation	HP Part Number	C D	Qty	Description	Mfr Code	Mfr Part Number
FB301	9100-1788	6	1	CORE-FERRITE CHOKE-WIDEBAND IMP:680 OHM	01887	VK200 20/48
FB401	9100-1788	6	1	CORE-FERRITE CHOKE-WIDEBAND IMP:680 OHM	01887	VK200 20/48
FB402	9100-1788	6	1	CORE-FERRITE CHOKE-WIDEBAND IMP:680 OHM	01887	VK200 20/48
J1	1252-2907	6	1	CONN MOD0 60 F2R	02946	65781-102
J2	1252-1284	0	1	CONN-POST TYPE .100-PIN-SPCG 40-CONT	01380	746865-9
J3	1252-2152	3	1	CONN-POST TYPE .100-PIN-SPCG 3-CONT	02946	69167-103
J4	1252-1470	6	1	CONN-POST TYPE .100-PIN-SPCG 40-CONT	01380	103922-1
J5	1250-1846	6	1	CONNECTOR-RF BNC FEM PC 50-OHM	01380	87-3331-014
J6	1252-1327	2	1	CONN-RECT D-SUBMIN 9-CKT 9-CONT	01380	745781-6
J7	1250-1846	6	1	CONNECTOR-RF BNC FEM PC 50-OHM	01380	87-3331-014
J8	1252-2162	5	1	CONN-POST TYPE .100-PIN-SPCG 5-CONT	02946	78208-105
J9	1252-1882	4	1	CONN-POST TYPE .100-PIN-SPCG 3-CONT	02946	78208-103
J10	1252-1065	5	1	CONN-POST TYPE .100-PIN-SPCG 24-CONT	01380	746878-5
J11	1252-3156	9	1	CONN-POST TYPE .100-PIN-SPCG 2-CONT	02946	79275-103
L1	9100-1631	8	1	INDUCTOR RF-CH-MLD 56UH +-5% .166D-INX.3	03273	15M562J
L201	9100-1631	8	1	INDUCTOR RF-CH-MLD 56UH +-5% .166D-INX.3	03273	15M562J
L301	9140-0736	6	1	INDUCTOR-FIXED L:200 UH MIN @ 0.35 ADC,1	04200	
MP2	1200-1314	8	4	SOCKET-IC-DIP 32-CONT DIP DIP-SLDR	01380	2-644018-1
MP3	1200-1208	9	1	SOCKET-IC 24-CONT DIP DIP-SLDR	01380	2-641932-1
MP6	0361-1310	3	2		07821	D30-0125-07
MP100	1200-1274	9	2	SOCKET-IC 68-CONT SQUARE DIP-SLDR	01380	821574-1
MP102	1200-1426	3	1	SOCKET PLCC 28 CONT	01380	821581-1
MP103	1400-1267	4	1	HOLDER-BAT .531-.656-DIA FOR AA CELLS	05535	91
MP104	0361-0026	6	2	RIVET-SEMITUB OVH .089DIA .125LG	02531	R-4008-1/8
MP105	5041-8959	7	1	INSULATOR - PROC	28480	5041-8959
MP107	0515-0169	5	2	SCREW-MACHINE ASSEMBLY M3 X 0.5 10MM-LG	01125	
MP108	0535-0025	4	2	NUT-HEX DBL-CHAM M3 X 0.5 2.4MM-THK	06691	
Q3	1855-0420	2	1	TRANSISTOR J-FET 2N4391 N-CHAN D-MODE TO	02037	2N4391
Q4	1853-0007	7	1	TRANSISTOR PNP 2N3251 SI TO-18 PD=360MW	02037	2N3251
Q5	1855-0420	2	1	TRANSISTOR J-FET 2N4391 N-CHAN D-MODE TO	02037	2N4391
Q6	1855-0276	6	1	TRANSISTOR J-FET 2N4416A N-CHAN D-MODE T	02037	2N4416A
Q7	1855-0420	2	1	TRANSISTOR J-FET 2N4391 N-CHAN D-MODE TO	02037	2N4391
Q8	1855-0675	9	1	TRANSISTOR MOSFET N-CHAN E-MODE SI	02037	MPF6660
Q201	1854-0215	1	1	TRANSISTOR NPN SI TO-92 PD=625MW FT=300M	00746	2N3904
Q301	1854-0215	1	1	TRANSISTOR NPN SI TO-92 PD=625MW FT=300M	00746	2N3904
Q302	1854-0215	1	1	TRANSISTOR NPN SI TO-92 PD=625MW FT=300M	00746	2N3904
Q303	1854-0215	1	1	TRANSISTOR NPN SI TO-92 PD=625MW FT=300M	00746	2N3904
R5	0698-7260	7	1	RESISTOR 10K +-1% .05W TF TC=0+-100	00746	CRB20
R6	0698-7260	7	1	RESISTOR 10K +-1% .05W TF TC=0+-100	00746	CRB20
R8	0698-7231	2	1	RESISTOR 619 +-1% .05W TF TC=0+-100	00746	CRB20
R9	0698-7212	9	1	RESISTOR 100 +-1% .05W TF TC=0+-100	00746	CRB20
R10	0698-7236	7	1	RESISTOR 1K +-1% .05W TF TC=0+-100	00746	CRB20
R11	0698-7236	7	1	RESISTOR 1K +-1% .05W TF TC=0+-100	00746	CRB20
R19	0698-7260	7	1	RESISTOR 10K +-1% .05W TF TC=0+-100	00746	CRB20
R20	0698-7260	7	1	RESISTOR 10K +-1% .05W TF TC=0+-100	00746	CRB20
R21	0698-7260	7	1	RESISTOR 10K +-1% .05W TF TC=0+-100	00746	CRB20
R23	0698-7196	8	1	RESISTOR 21.5 +-1% .05W TF TC=0+-100	00746	CRB20

HP Part Number 08592-60068
Processor/Video

Reference Designation	HP Part Number	C	D	Qty	Description	Mfr Code	Mfr Part Number
R27	0698-7248	1		1	RESISTOR 3.16K +-1% .05W TF TC=0+-100	00746	CRB20
R28	0698-7214	1		1	RESISTOR 121 +-1% .05W TF TC=0+-100	00746	CRB20
R29	0698-7284	5		1	RESISTOR 100K +-1% .05W TF TC=0+-100	00746	CRB20
R30	0698-7277	6		1	RESISTOR 51.1K +-1% .05W TF TC=0+-100	00746	CRB20
R31	0698-7225	4		1	RESISTOR 348 +-1% .05W TF TC=0+-100	00746	CRB20
R32	0698-7258	3		1	RESISTOR 8.25K +-1% .05W TF TC=0+-100	00746	CRB20
R33	0698-7255	0		1	RESISTOR 6.19K +-1% .05W TF TC=0+-100	00746	CRB20
R34	0698-7248	1		1	RESISTOR 3.16K +-1% .05W TF TC=0+-100	00746	CRB20
R35	0698-7220	9		1	RESISTOR 215 +-1% .05W TF TC=0+-100	00746	CRB20
R36	0698-7212	9		1	RESISTOR 100 +-0.1% .05W TF TC=0+-100	00746	CRB20
R37	0698-6320	8		1	RESISTOR 5K +-0.1% .125W TF TC=0+-25	00746	CRB14 OR CRB25
R38	0698-7260	7		1	RESISTOR 10K +-1% .05W TF TC=0+-100	00746	CRB20
R39	0698-7247	0		1	RESISTOR 2.87K +-1% .05W TF TC=0+-100	00746	CRB20
R40	0698-7221	0		1	RESISTOR 237 +-1% .05W TF TC=0+-100	00746	CRB20
R41	0698-6317	3		1	RESISTOR 500 +-0.1% .125W TF TC=0+-25	00746	CRB14 OR CRB25
R42	0698-6317	3		1	RESISTOR 500 +-0.1% .125W TF TC=0+-25	00746	CRB14 OR CRB25
R43	0698-6362	8		1	RESISTOR 1K +-0.1% .125W TF TC=0+-25	00746	CRB14 OR CRB25
R44	0698-6317	3		1	RESISTOR 500 +-0.1% .125W TF TC=0+-25	00746	CRB14 OR CRB25
R45	0698-7202	7		1	RESISTOR 38.3 +-1% .05W TF TC=0+-100	00746	CRB20
R46	0698-7202	7		1	RESISTOR 38.3 +-1% .05W TF TC=0+-100	00746	CRB20
R47	0698-7218	5		1	RESISTOR 178 +-1% .05W TF TC=0+-100	00746	CRB20
R48	0698-7236	7		1	RESISTOR 1K +-1% .05W TF TC=0+-100	00746	CRB20
R49	0698-7250	5		1	RESISTOR 3.83K +-1% .05W TF TC=0+-100	00746	CRB20
R51	0698-7277	6		1	RESISTOR 51.1K +-1% .05W TF TC=0+-100	00746	CRB20
R52	0698-6362	8		1	RESISTOR 1K +-0.1% .125W TF TC=0+-25	00746	CRB14 OR CRB25
R53	0698-6347	9		1	RESISTOR 1.5K +-0.1% .125W TF TC=0+-25	00746	CRB14 OR CRB25
R54	0698-7284	5		1	RESISTOR 100K +-1% .05W TF TC=0+-100	00746	CRB20
R55	0698-7212	9		1	RESISTOR 100 +-1% .05W TF TC=0+-100	00746	CRB20
R56	0698-7248	1		1	RESISTOR 3.16K +-1% .05W TF TC=0+-100	00746	CRB20
R57	0698-7248	1		1	RESISTOR 3.16K +-1% .05W TF TC=0+-100	00746	CRB20
R58	0698-7248	1		1	RESISTOR 3.16K +-1% .05W TF TC=0+-100	00746	CRB20
R60	0698-7260	7		1	RESISTOR 10K +-1% .05W TF TC=0+-100	00746	CRB20
R61	0698-7284	5		1	RESISTOR 100K +-1% .05W TF TC=0+-100	00746	CRB20
R62	0698-7277	6		1	RESISTOR 51.1K +-1% .05W TF TC=0+-100	00746	CRB20
R63	0698-7284	5		1	RESISTOR 100K +-1% .05W TF TC=0+-100	00746	CRB20
R64	0698-6317	3		1	RESISTOR 500 +-0.1% .125W TF TC=0+-25	00746	CRB14 OR CRB25
R65	0698-6360	6		1	RESISTOR 10K +-0.1% .125W TF TC=0+-25	00746	CRB14 OR CRB25
R66	0698-7205	0		1	RESISTOR 51.1 +-1% .05W TF TC=0+-100	00746	CRB20
R67	0698-6631	4		1	RESISTOR 2.5K +-0.1% .125W TF TC=0+-25	00746	CRB14 OR CRB25
R68	0698-6360	6		1	RESISTOR 10K +-0.1% .125W TF TC=0+-25	00746	CRB14 OR CRB25
R69	0698-7205	0		1	RESISTOR 51.1 +-1% .05W TF TC=0+-100	00746	CRB20
R70	0698-7260	7		1	RESISTOR 10K +-1% .05W TF TC=0+-100	00746	CRB20
R71	0698-7260	7		1	RESISTOR 10K +-1% .05W TF TC=0+-100	00746	CRB20
R72	0698-7221	0		1	RESISTOR 237 +-1% .05W TF TC=0+-100	00746	CRB20
R78	0698-7260	7		1	RESISTOR 10K +-1% .05W TF TC=0+-100	00746	CRB20
R101	0698-7260	7		1	RESISTOR 10K +-1% .05W TF TC=0+-100	00746	CRB20
R102	0698-7260	7		1	RESISTOR 10K +-1% .05W TF TC=0+-100	00746	CRB20

**Indicates factory-selected value*

HP Part Number 08592-60068
Processor/Video

Reference Designation	HP Part Number	C D	Qty	Description	Mfr Code	Mfr Part Number
R103	0698-7236	7	1	RESISTOR 1K +-1% .05W TF TC=0+-100	00746	CRB20
R105	0698-7245	8	1	RESISTOR 2.37K +-1% .05W TF TC=0+-100	00746	CRB20
R106	0698-7260	7	1	RESISTOR 10K +-1% .05W TF TC=0+-100	00746	CRB20
R107	0698-7260	7	1	RESISTOR 10K +-1% .05W TF TC=0+-100	00746	CRB20
R108	0698-7260	7	1	RESISTOR 10K +-1% .05W TF TC=0+-100	00746	CRB20
R109	0698-7260	7	1	RESISTOR 10K +-1% .05W TF TC=0+-100	00746	CRB20
R110	0698-7260	7	1	RESISTOR 10K +-1% .05W TF TC=0+-100	00746	CRB20
R111	0698-7236	7	1	RESISTOR 1K +-1% .05W TF TC=0+-100	00746	CRB20
R201	0698-7188	8	1	RESISTOR 10 +-1% .05W TF TC=0+-100	00746	CRB20
R202	0698-7212	9	1	RESISTOR 100 +-1% .05W TF TC=0+-100	00746	CRB20
R203	0698-7253	8	1	RESISTOR 5.11K +-1% .05W TF TC=0+-100	00746	CRB20
R204	0698-7260	7	1	RESISTOR 10K +-1% .05W TF TC=0+-100	00746	CRB20
R205	0698-7243	6	1	RESISTOR 1.96K +-1% .05W TF TC=0+-100	00746	CRB20
R206	0698-7253	8	1	RESISTOR 5.11K +-1% .05W TF TC=0+-100	00746	CRB20
R207	0698-7260	7	1	RESISTOR 10K +-1% .05W TF TC=0+-100	00746	CRB20
R208	0698-7253	8	1	RESISTOR 5.11K +-1% .05W TF TC=0+-100	00746	CRB20
R209	0698-7277	6	1	RESISTOR 51.1K +-1% .05W TF TC=0+-100	00746	CRB20
R210	0698-7277	6	1	RESISTOR 51.1K +-1% .05W TF TC=0+-100	00746	CRB20
R301	0698-7243	6	1	RESISTOR 1.96K +-1% .05W TF TC=0+-100	00746	CRB20
R302	0698-7212	9	1	RESISTOR 100 +-1% .05W TF TC=0+-100	00746	CRB20
R303	0698-7221	0	1	RESISTOR 237 +-1% .05W TF TC=0+-100	00746	CRB20
R304	0698-7242	5	1	RESISTOR 1.78K +-1% .05W TF TC=0+-100	00746	CRB20
R305	0698-7224	3	1	RESISTOR 316 +-1% .05W TF TC=0+-100	00746	CRB20
R306	0698-7253	8	1	RESISTOR 5.11K +-1% .05W TF TC=0+-100	00746	CRB20
R307	0698-7208	3	1	RESISTOR 68.1 +-1% .05W TF TC=0+-100	00746	CRB20
R308	0698-7234	5	1	RESISTOR 825 +-1% .05W TF TC=0+-100	00746	CRB20
R309	0698-7201	6	1	RESISTOR 34.8 +-1% .05W TF TC=0+-100	00746	CRB20
R310	0757-0402	1	1	RESISTOR 110 +-1% .125W TF TC=0+-100	00746	CRB14 OR CRB25
R311	0698-7230	1	1	RESISTOR 562 +-1% .05W TF TC=0+-100	00746	CRB20
R312	0698-7224	3	1	RESISTOR 316 +-1% .05W TF TC=0+-100	00746	CRB20
R313	0698-7209	4	1	RESISTOR 75 +-1% .05W TF TC=0+-100	00746	CRB20
R314	0698-7260	7	1	RESISTOR 10K +-1% .05W TF TC=0+-100	00746	CRB20
R315	0698-7245	8	1	RESISTOR 2.37K +-1% .05W TF TC=0+-100	00746	CRB20
R316	0698-7260	7	1	RESISTOR 10K +-1% .05W TF TC=0+-100	00746	CRB20
R317	0698-7260	7	1	RESISTOR 10K +-1% .05W TF TC=0+-100	00746	CRB20
R318	0698-7260	7	1	RESISTOR 10K +-1% .05W TF TC=0+-100	00746	CRB20
TP1	1251-5596	3	1	CONN-POST TYPE .100-PIN-SPCG 7-CONT	02946	68001-607
U2	1820-6218	5	1	IC TRANSCEIVER CMOS/74HC BUS OCTL	02037	MC74HC646N
U3	1820-6218	5	1	IC TRANSCEIVER CMOS/74HC BUS OCTL	02037	MC74HC646N
U4	1818-4017	3	1	IC CMOS 262144 (256K) STAT RAM 100-NS 3	06354	TC55257BPL-10
U5	1818-4017	3	1	IC CMOS 262144 (256K) STAT RAM 100-NS 3	06354	TC55257BPL-10
U6		4	1	PROGRAMMED EPROM U6 SEE SVC MNL	28480	
U7		5	1	PROGRAMMED EPROM U7 SEE SVC MNL	28480	
U9	1820-3298	5	1	IC GATE CMOS/74HC OR QUAD 2-INP	02037	MC74HC32N
U10	1820-3097	2	1	IC GATE CMOS/74HC AND QUAD 2-INP	02037	MC74HC08N
U11	1810-0286	4	1	NETWORK-RES 16-DIP 10.0K OHM X 15	02483	761-1-R10K
U12	1820-5844	1	1	IC-16-BIT MPU W/COUNTER, PLCC 8MHZ	02037	MC68HC000FN8
U13	1820-3173	5	1	IC FF CMOS/74HC J-K NEG-EDGE-TRIG PRESET	02037	MC74HC112N

HP Part Number 08592-60068
Processor/Video

Reference Designation	HP Part Number	C D	Qty	Description	Mfr Code	Mfr Part Number
U16	1820-3183	7	1	IC GATE CMOS/74HC NAND QUAD 2-INP	02037	MC74HC03N
U18	1820-2998	0	1	IC LCH CMOS/74HC TRANSPARENT OCTL	01698	SN74HC373N
U19	1820-3789	9	1	IC FF CMOS/74HC D-TYPE POS-EDGE-TRIG COM	02037	MC74HC574N
U20	1820-3789	9	1	IC FF CMOS/74HC D-TYPE POS-EDGE-TRIG COM	02037	MC74HC574N
U21	1818-4017	3	1	IC CMOS 262144 (256K) STAT RAM 100-NS 3	06354	TC55257BPL-10
U22	1818-4017	3	1	IC CMOS 262144 (256K) STAT RAM 100-NS 3	06354	TC55257BPL-10
U23		6	1	PROGRAMMED EPROM U23 SEE SVC MNL	28480	
U24		7	1	PROGRAMMED EPROM U24 SEE SVC MNL	28480	
U25	1251-4787	2	1	SHUNT-DIP 8 POSITION DUAL INLINE PKG	01380	435704-8
U26	1820-3080	3	1	IC GATE CMOS/74HC NAND DUAL 4-INP	02037	MC74HC20N
U32	1820-2922	0	1	IC GATE CMOS/74HC NAND QUAD 2-INP	02037	MC74HC00N
U33	1858-0077	1	1	TRANSISTOR ARRAY 14-PIN PLSTC TO-116	02037	MPQ2222P
U34	1810-0037	3	1	NETWORK-RES 16-DIP 1.0K OHM X 8	02483	761-3-R1K
U35	1826-0759	9	1	IC COMPARATOR GP QUAD 14-DIP-C PKG	02037	LM339J
U36	1820-3205	4	1	IC CNTR CMOS/74HC BIN UP/DOWN SYNCHRO PO	03406	MM74HC193N
U37	1820-3081	4	1	IC FF CMOS/74HC D-TYPE POS-EDGE-TRIG PRE	01698	SN74HC74N
U38	1810-0206	8	1	NETWORK-RES 8-SIP 10.0K OHM X 7	02483	750-81
U39	1820-2922	0	1	IC GATE CMOS/74HC NAND QUAD 2-INP	02037	MC74HC00N
U40	1820-5108	0	1	IC-PROGRAMMABLE INTERVAL TIMER 8MHZ CMOS	03811	N82C54
U41	1820-3298	5	1	IC GATE CMOS/74HC OR QUAD 2-INP	02037	MC74HC32N
U42	1820-3298	5	1	IC GATE CMOS/74HC OR QUAD 2-INP	02037	MC74HC32N
U44	1858-0077	1	1	TRANSISTOR ARRAY 14-PIN PLSTC TO-116	02037	MPQ2222P
U45	1826-1045	8	1	IC OP AMP H-SLEW-RATE 8-DIP-C PKG	03799	HA7-2515-5
U46	1826-1178	8	1	SAMPLE AND HOLD 14 -CERDIP	03799	HA1-5320-5
U47	1826-1522	6	1	A/D 12-DGT 28-CERDIP HYB	03285	AD574AJ (SELECTED)
U48	1810-0286	4	1	NETWORK-RES 16-DIP 10.0K OHM X 15	02483	761-1-R10K
U49	1820-3789	9	1	IC FF CMOS/74HC D-TYPE POS-EDGE-TRIG COM	02037	MC74HC574N
U52	1820-3079	0	1	IC DCDR CMOS/74HC BIN 3-TO-8-LINE	02037	MC74HC138N
U53	1810-0286	4	1	NETWORK-RES 16-DIP 10.0K OHM X 15	02483	761-1-R10K
U54	1820-3297	4	1	IC DRVR CMOS/74HC BUS OCTL	02037	MC74HC244N
U56	1820-4675	4	1	IC ENCDR CMOS/74HC PRIORITY 8-TO-3-LINE	01698	SN74HC148N
U57	1820-3449	8	1	IC-PARALLEL INTERFACE/TIMER/8MHZ/MC68000	02037	MC68230L8
U58	1810-0205	7	1	NETWORK-RES 8-SIP 4.7K OHM X 7	02483	750-81
U60	1810-0203	5	1	NETWORK-RES 8-SIP 470.0 OHM X 7	02483	750-81
U61	1826-1939	9	1	IC OP AMP WB 8-TO-99 PKG	03799	HA2-5160-5
U62	1858-0032	8	1	TRANSISTOR ARRAY 14-PIN PLSTC DIP	03406	LM3146
U63	1858-0077	1	1	TRANSISTOR ARRAY 14-PIN PLSTC TO-116	02037	MPQ2222P
U64	1826-0609	8	1	ANALOG MULTIPLEXER 8 CHNL 16 -CERDIP	02180	MUX-08FQ
U65	1820-3789	9	1	IC FF CMOS/74HC D-TYPE POS-EDGE-TRIG COM	02037	MC74HC574N
U66	1820-3789	9	1	IC FF CMOS/74HC D-TYPE POS-EDGE-TRIG COM	02037	MC74HC574N
U68	1820-3297	4	1	IC DRVR CMOS/74HC BUS OCTL	02037	MC74HC244N
U71	1820-3081	4	1	IC FF CMOS/74HC D-TYPE POS-EDGE-TRIG PRE	01698	SN74HC74N
U72	1820-3185	9	1	IC SCHMITT-TRIG CMOS/74HC INV HEX	02037	MC74HC14N
U101	08590-80093	4	1	PAL PROGRAMMED U101	28480	08590-80093
U102	1820-3174	6	1	IC SCHMITT-TRIG CMOS/74HC NAND QUAD 2-IN	02037	MC74HC132N
U103	1820-5497	0	1	IC-NONVOLATILE MEMORY CONTROLLER	12186	DS1210
U104	1826-1858	1	1	IC MISC 16-DIP-P PKG	12186	DS1259N

**Indicates factory-selected value*

HP Part Number 08592-60068
Processor/Video

Reference Designation	HP Part Number	C D	Qty	Description	Mfr Code	Mfr Part Number
U105	1820-5497	0	1	IC-NONVOLATILE MEMORY CONTROLLER	12186	DS1210
U106	1820-5384	4	1	IC-INTERFACE CMOS -888-BIT	10421	RTC-72421B
U107	1810-0280	8	1	NETWORK-RES 10-SIP 10.0K OHM X 9	02483	750-101
U108	1820-3789	9	1	IC FF CMOS/74HC D-TYPE POS-EDGE-TRIG COM	02037	MC74HC574N
U109	1810-0273	9	1	NETWORK-RES 10-SIP 470.0 OHM X 9	02483	750-101
U110	1810-0280	8	1	NETWORK-RES 10-SIP 10.0K OHM X 9	02483	750-101
U111	1820-3297	4	1	IC DRVR CMOS/74HC BUS OCTL	02037	MC74HC244N
U113	1820-3183	7	1	IC GATE CMOS/74HC NAND QUAD 2-INP	02037	MC74HC03N
U114	08590-80094	5	1	PAL PROGRAMMED U114	28480	08590-80094
U115	08590-80095	6	1	PAL PROGRAMMED U115	28480	08590-80095
U116	1820-3298	5	1	IC GATE CMOS/74HC OR QUAD 2-INP	02037	MC74HC32N
U117	1813-0129	0	1	CLOCK-OSCILLATOR-XTAL 14.7456-MHZ 0.01%	01417	HS-100(14.7456MHZ)
U118	1820-3537	5	1	IC FF CMOS/74HCT D-TYPE POS-EDGE-TRIG PR	02910	74HCT74N
U201	1826-0609	8	1	ANALOG MULTIPLEXER 8 CHNL 16 -CERDIP	02180	MUX-08FQ
U202	1826-1220	1	1	IC OP AMP WB 8-DIP-C PKG	03799	HA7-2525-5
U301	1820-6351	7	1	IC-CRT CONTROLLER 68-PLCC 8MHZ	02910	SCC63484C8A68
U302	1820-2656	7	1	IC GATE TTL/ALS NAND QUAD 2-INP	01698	SN74ALS00AN
U303	1820-2102	8	1	IC LCH TTL/LS TRANSPARENT OCTL	01698	SN74LS373N
U304	1820-2102	8	1	IC LCH TTL/LS TRANSPARENT OCTL	01698	SN74LS373N
U305	1818-4017	3	1	IC CMOS 262144 (256K) STAT RAM 100-NS 3	06354	TC55257BPL-10
U306	1818-4017	3	1	IC CMOS 262144 (256K) STAT RAM 100-NS 3	06354	TC55257BPL-10
U307	1813-0245	1	1	CLOCK-OSCILLATOR-XTAL 25.0-MHZ 0.05%	01417	HS-102-25.000MHZ
U308	08590-80096	7	1	PAL PROGRAMMED U308	28480	08590-80096
U309	1820-1922	8	1	IC SHF-RGTR TTL/LS SYNC/ASYNC PAR/SERIAL	01698	SN74LS166AN
U310	1820-1922	8	1	IC SHF-RGTR TTL/LS SYNC/ASYNC PAR/SERIAL	01698	SN74LS166AN
U311	1820-0535	7	1	IC-INTERFACE DRVR AND DUAL -888-BIT	01698	SN75451BP
U312	1820-0535	7	1	IC-INTERFACE DRVR AND DUAL -888-BIT	01698	SN75451BP
U401	1810-0301	4	1	NETWORK-RES 16-DIP 51.0 OHM X 8	02483	761-3-R51
U402	1810-0301	4	1	NETWORK-RES 16-DIP 51.0 OHM X 8	02483	761-3-R51
U403	1810-0301	4	1	NETWORK-RES 16-DIP 51.0 OHM X 8	02483	761-3-R51
U404	1810-0301	4	1	NETWORK-RES 16-DIP 51.0 OHM X 8	02483	761-3-R51
U405	1810-0301	4	1	NETWORK-RES 16-DIP 51.0 OHM X 8	02483	761-3-R51
U406	1810-0301	4	1	NETWORK-RES 16-DIP 51.0 OHM X 8	02483	761-3-R51
VR1	1902-0952	6	1	DIODE-ZNR 5.6V 5% DO-35 PD=.4W TC=+.046%	02037	
VR301	1902-0949	1	1	DIODE-ZNR 4.3V 5% DO-35 PD=.4W TC=+.017%	02037	
VR302	1902-0949	1	1	DIODE-ZNR 4.3V 5% DO-35 PD=.4W TC=+.017%	02037	
W102	8159-0005	0	1	RESISTOR 0 CWM	01339	L-2007-1
W103	8159-0005	0	1	RESISTOR 0 CWM	01339	L-2007-1
W104	8159-0005	0	1	RESISTOR 0 CWM	01339	L-2007-1

- NOTES: UNLESS OTHERWISE SPECIFIED
1. DIMENSIONS ARE IN INCHES.
 2. MAXIMUM COMPONENT HEIGHT .402
 3. MAXIMUM LEAD TRIM LENGTH .118
 4. MAXIMUM COMPONENT HEIGHT .502.
 5. CHECK FOR MODIFICATIONS IN THE P.C. LINE ASSEMBLY DOCUMENTATION MANUAL A-08590-115.

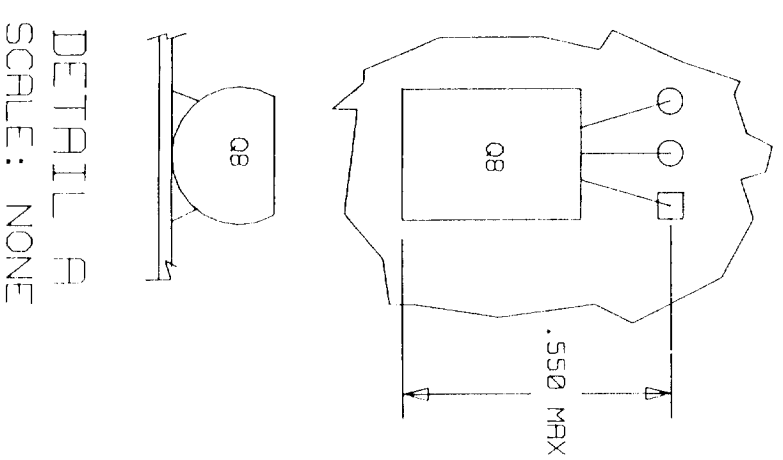
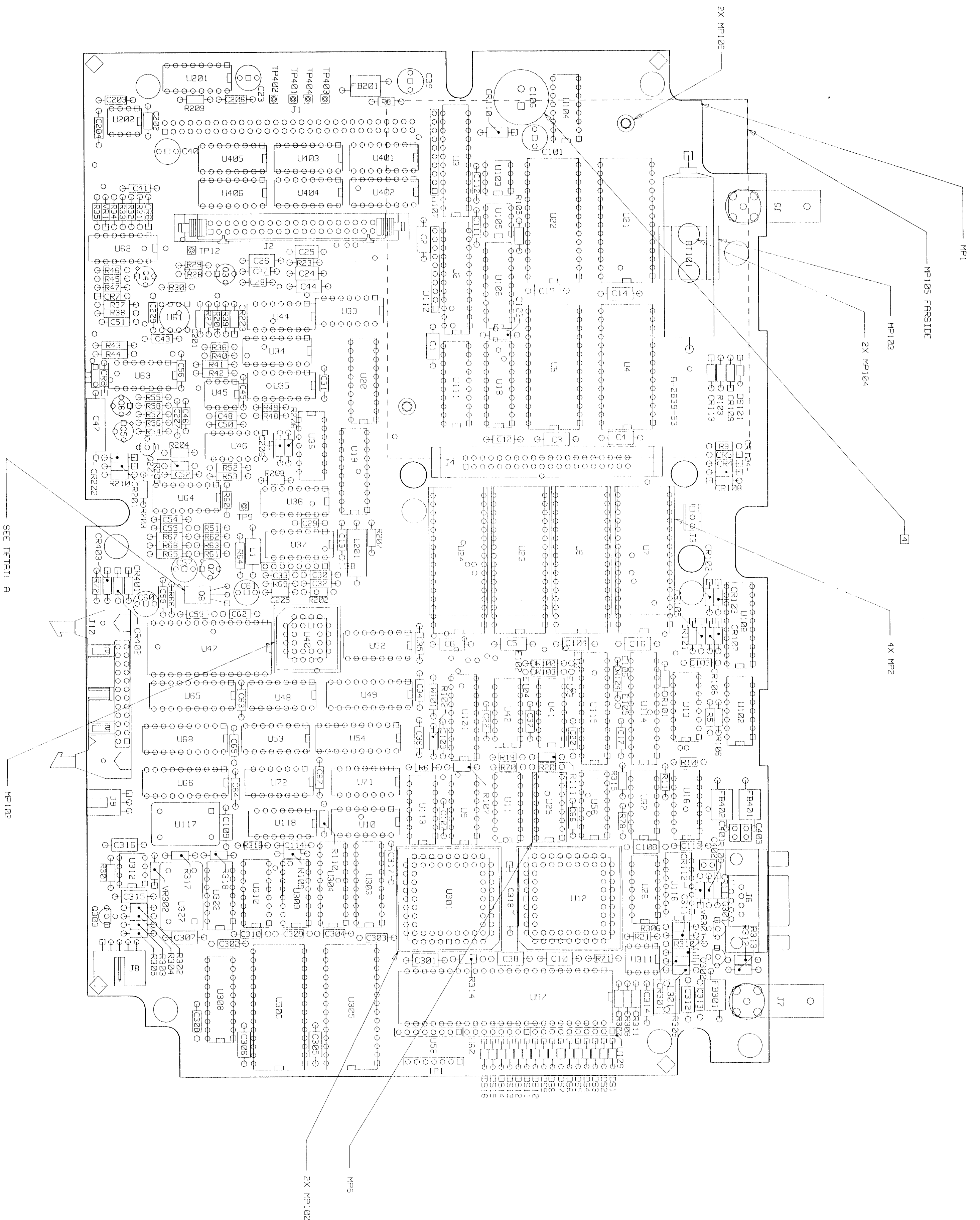

DETAIL R
SCALE: NONE

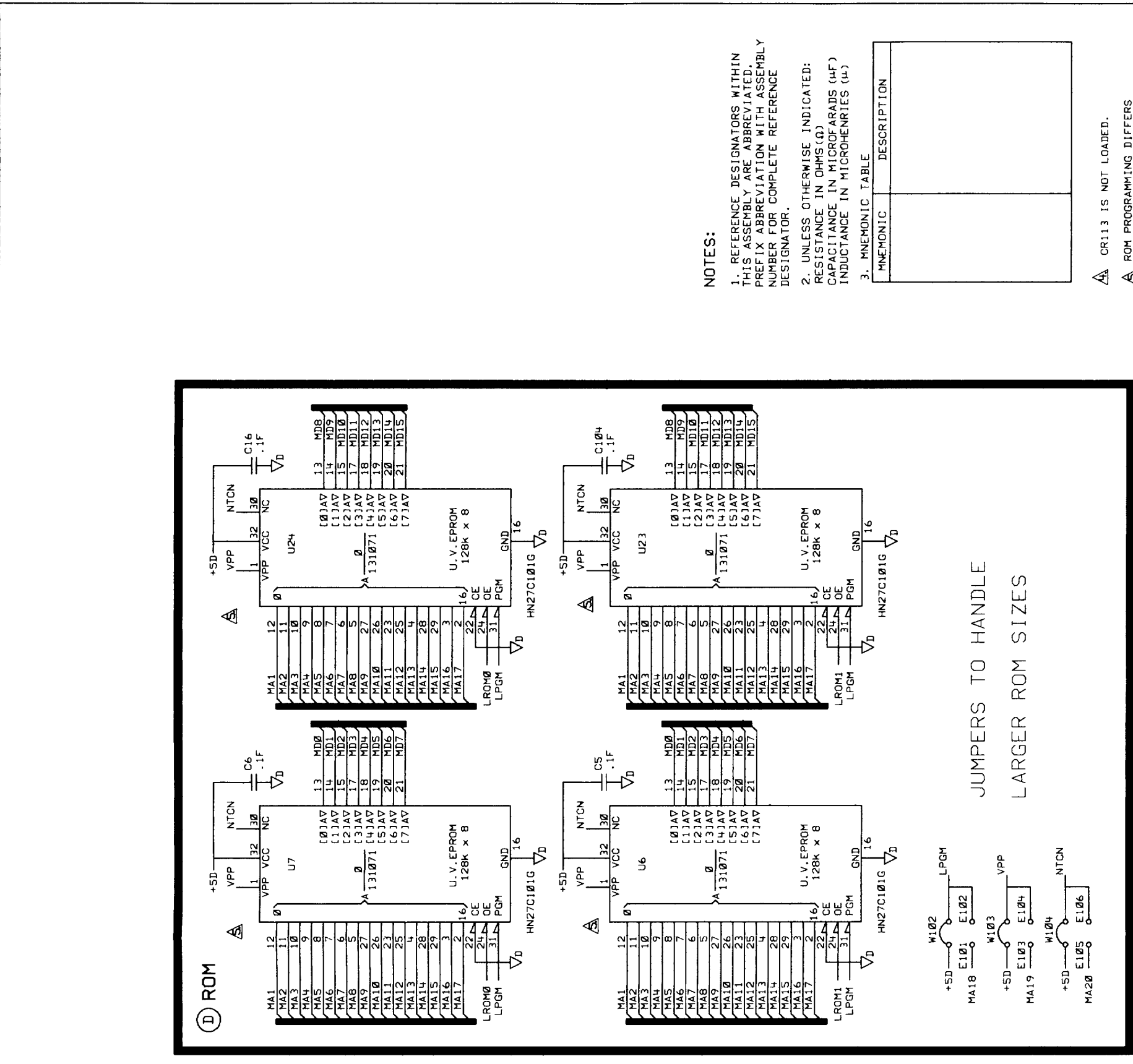
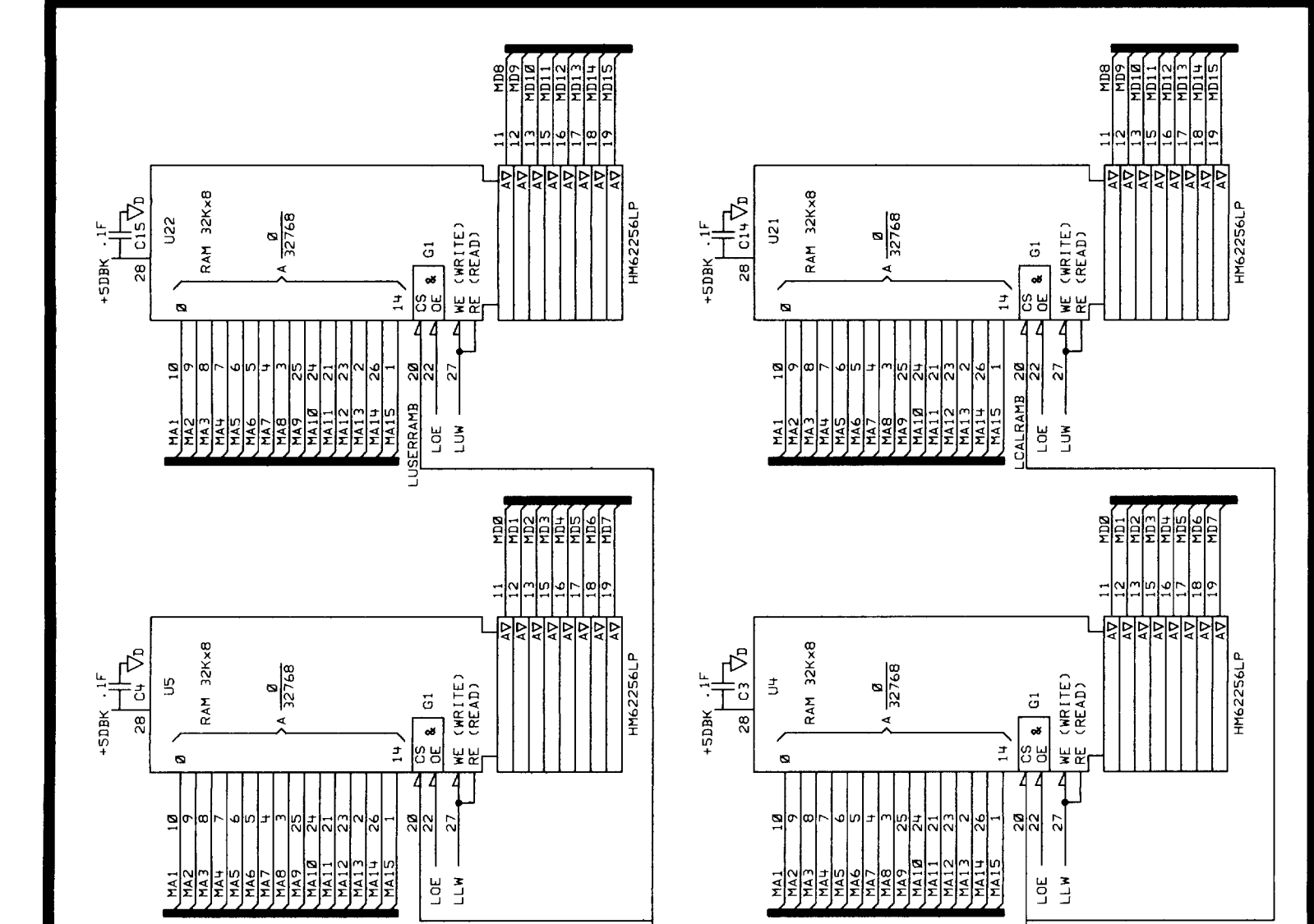
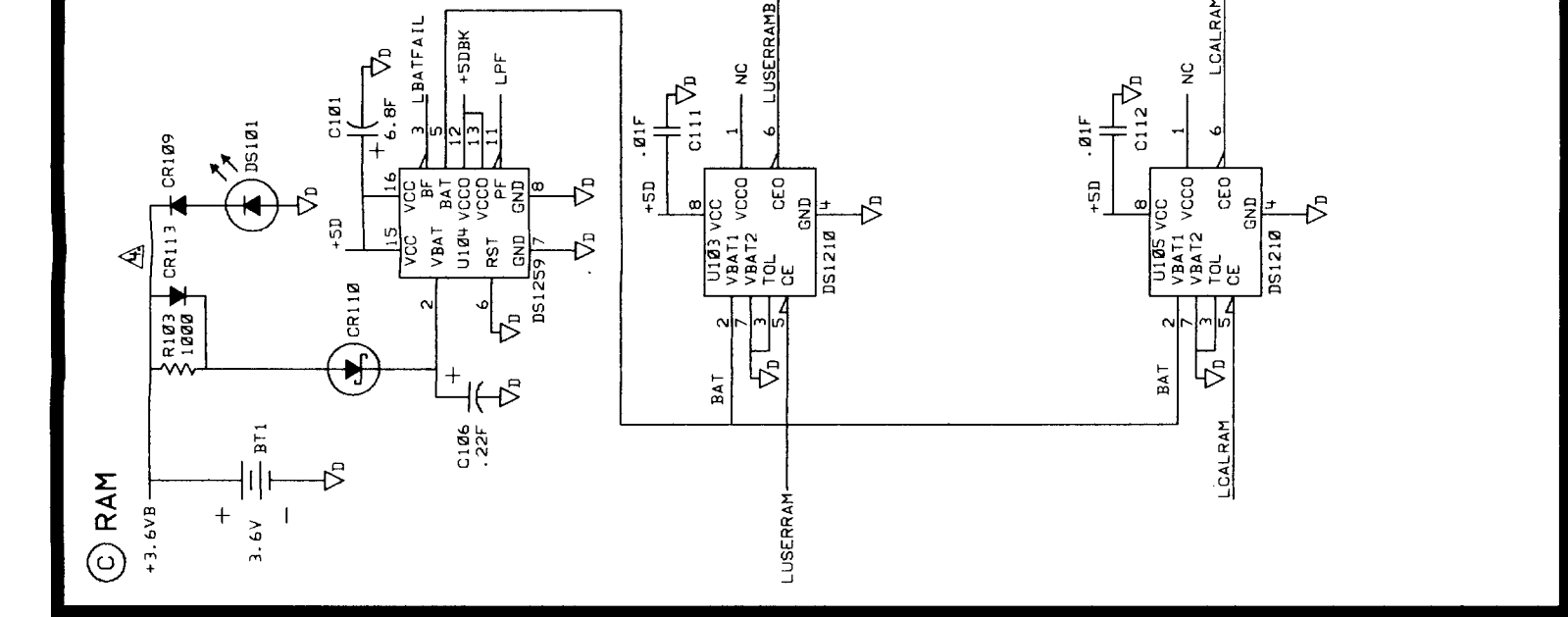
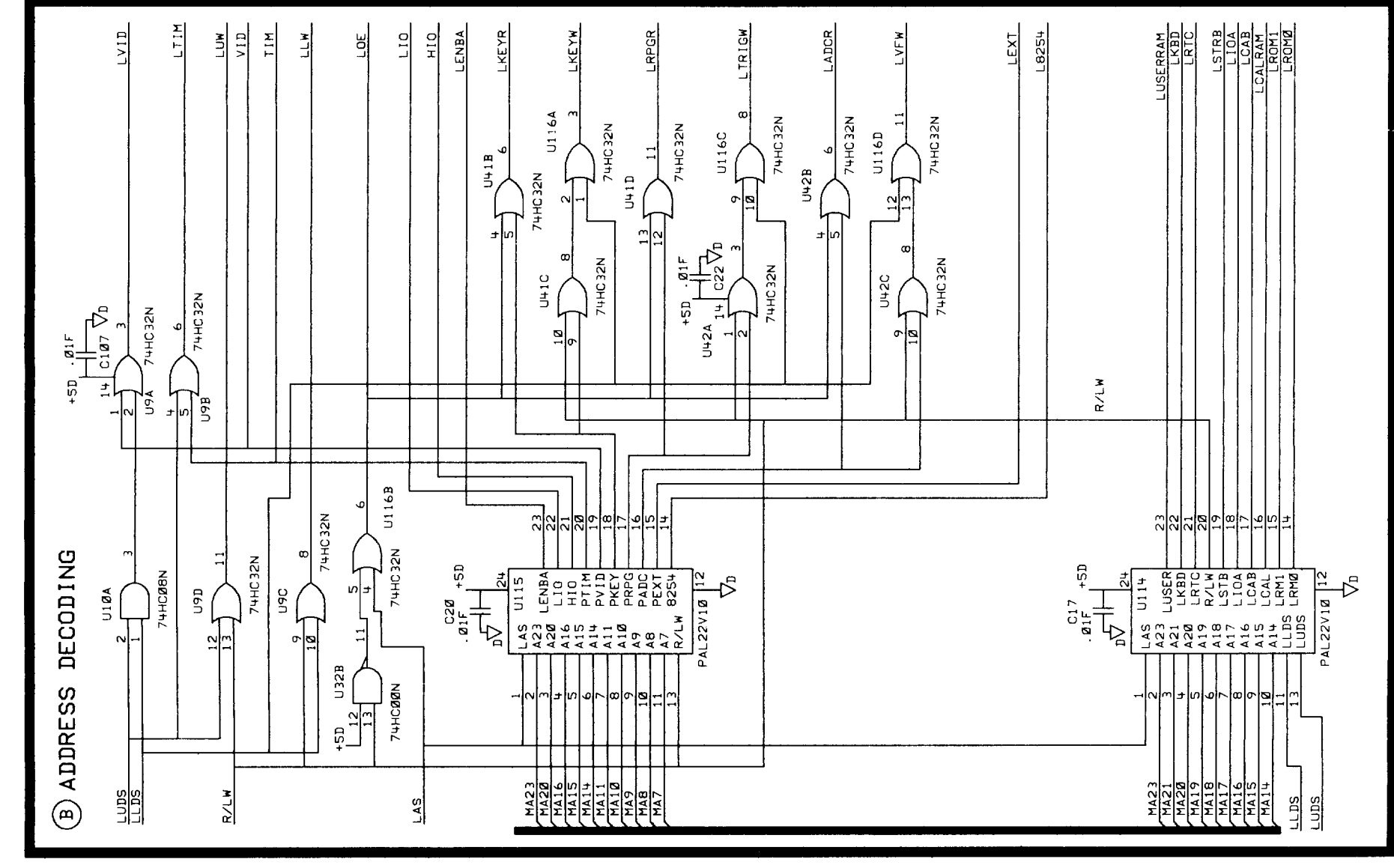

NOTES:
 1. REFERENCE DESIGNATORS WITHIN THIS ASSEMBLY ARE ABBREVIATED. NUMBER FOR COMPLETE REFERENCE DESIGNATION.
 2. CAPACITANCE IN MICROFARADS (UF) RESISTANCE IN OHMS (O).
 3. MECHANICAL TABLE

MECHANICAL TABLE	DESCRIPTION

OR113 IS NOT LOADED.
 ROM PROGRAMMING BUFFERS FOR 08592-60068

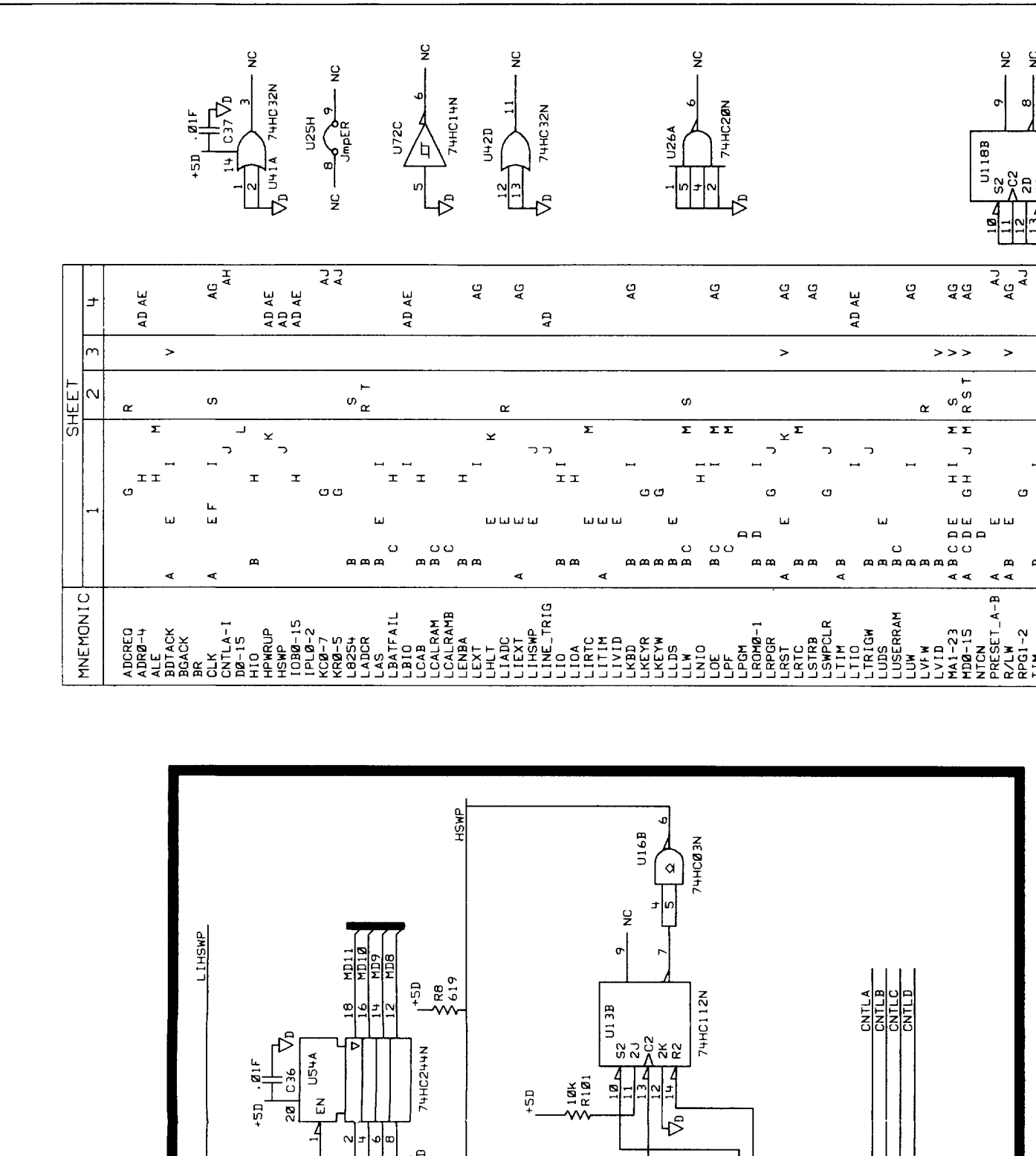
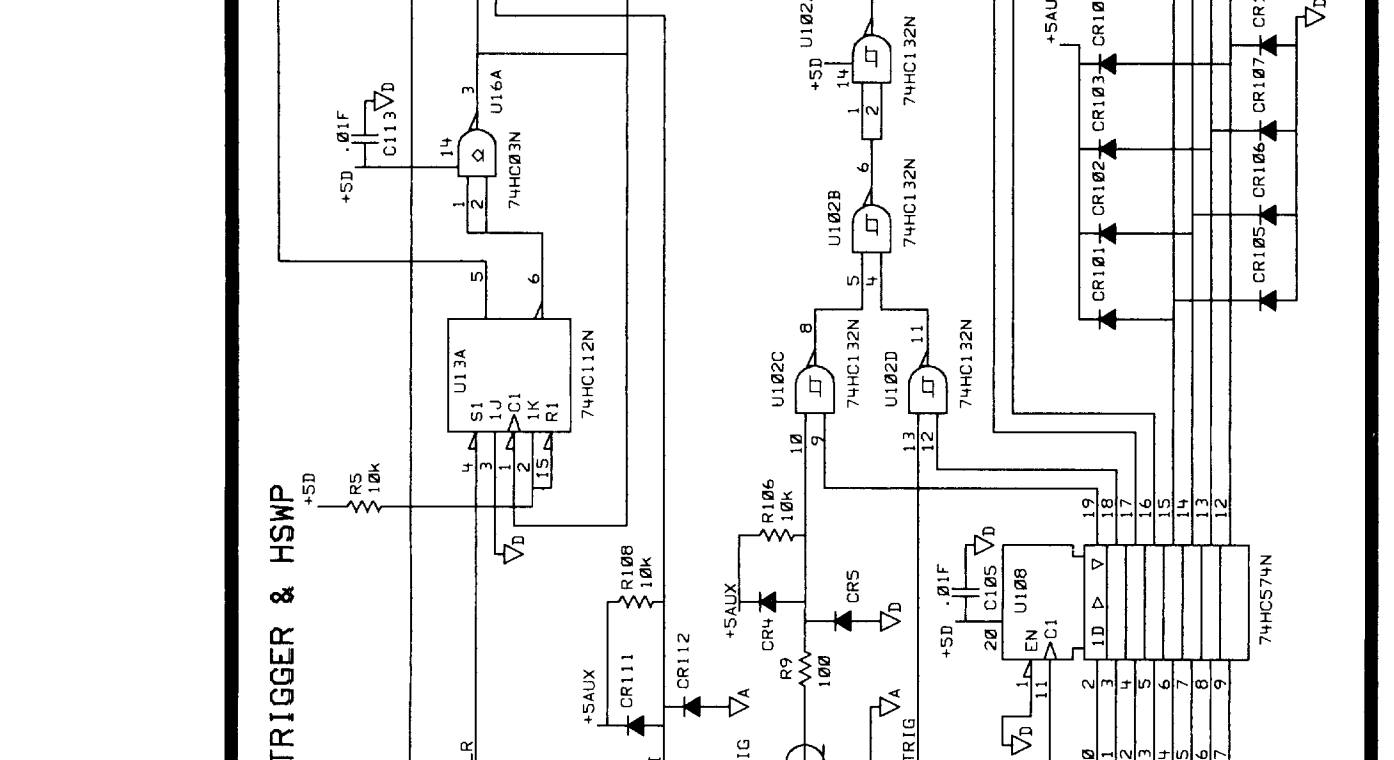
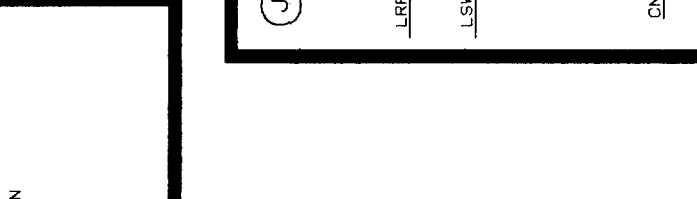
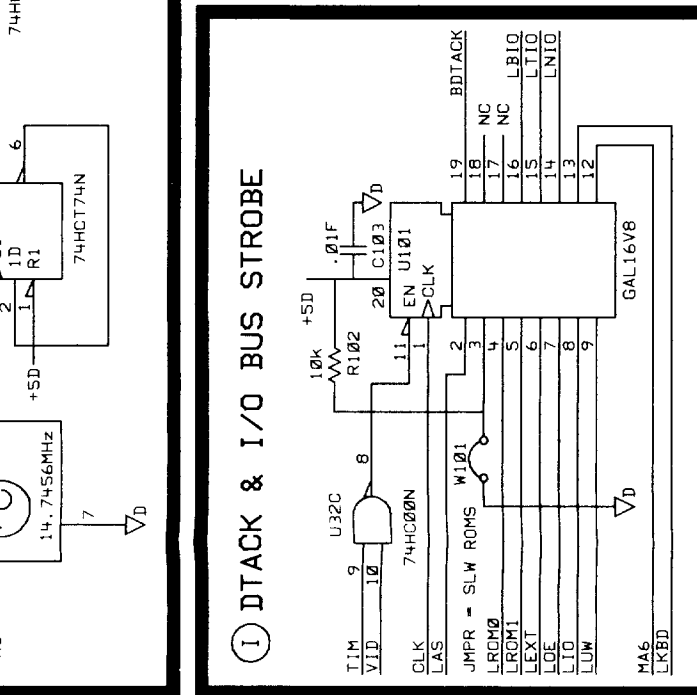
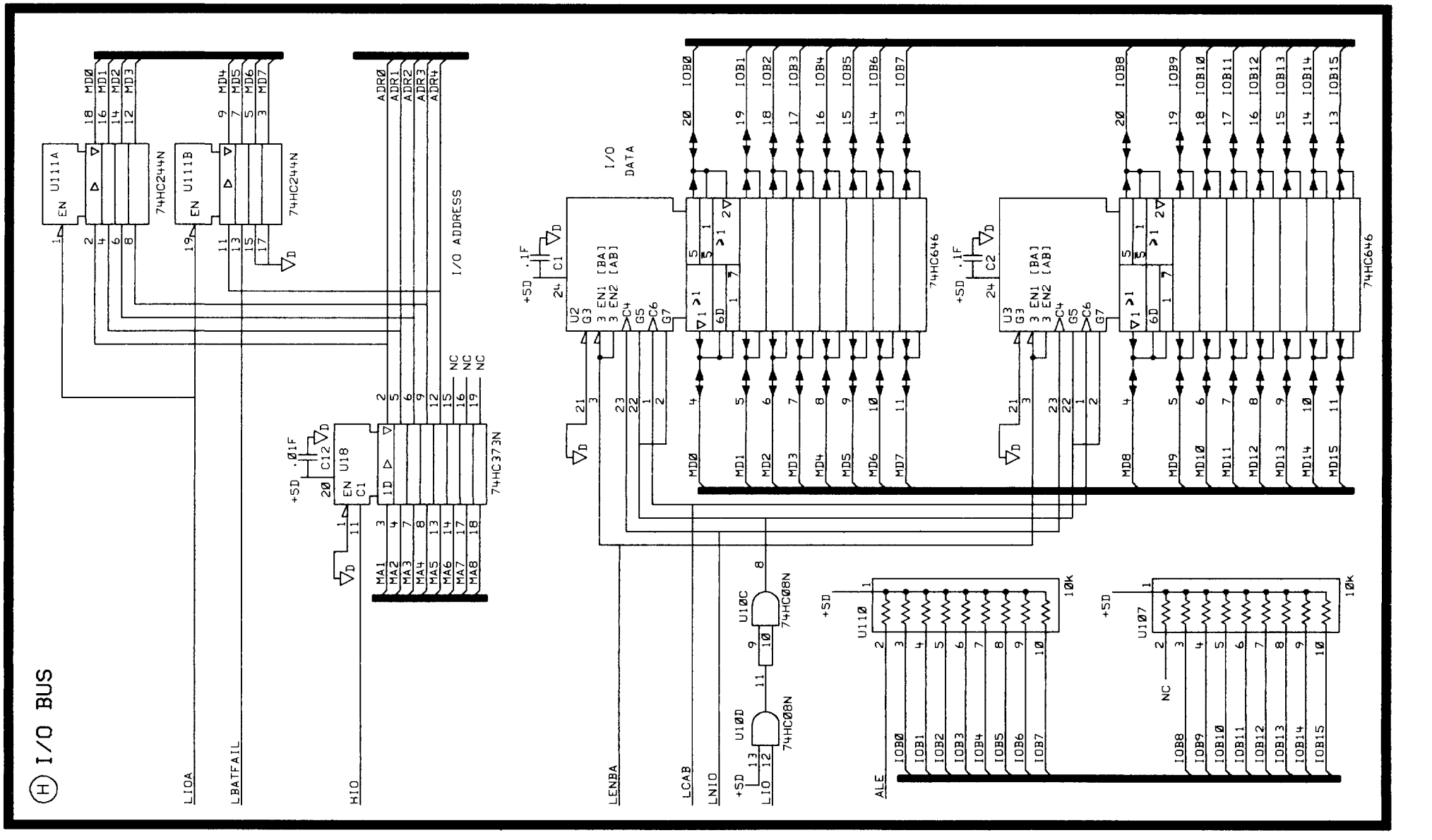
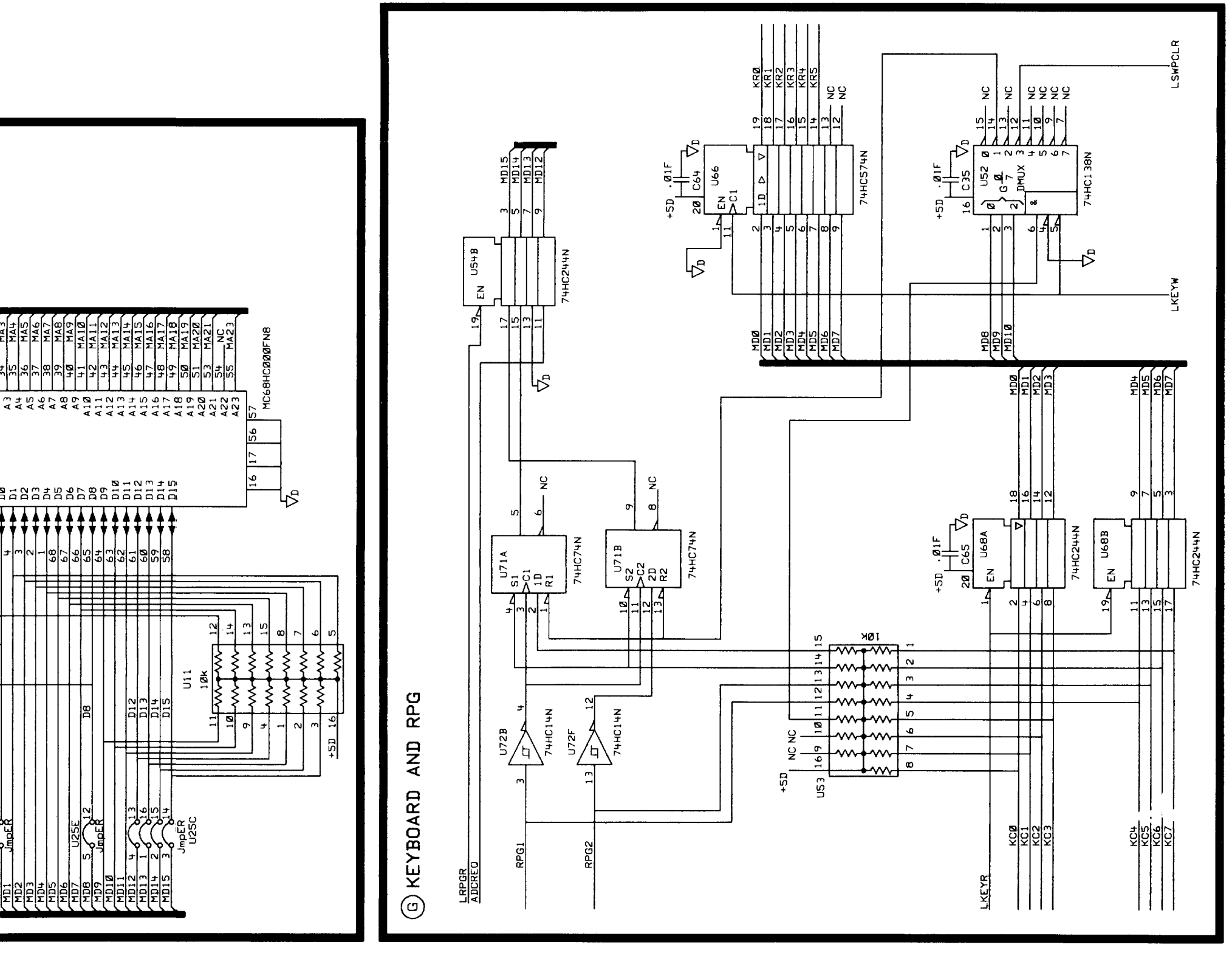

THIS DRAWING ALSO USED FOR THE FOLLOWING ASSEMBLIES:

PART NO.	MATERIAL LIST	REMARKS
08592-60102	08592-60068	
08592-60068	08592-60068	

TABLE 1

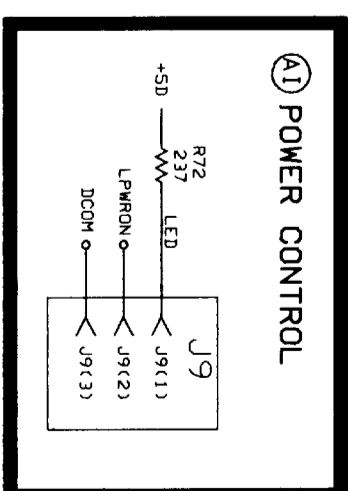
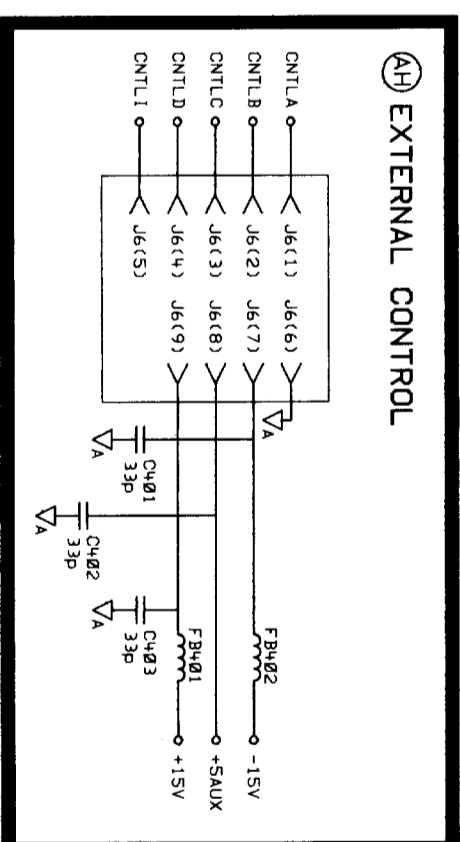
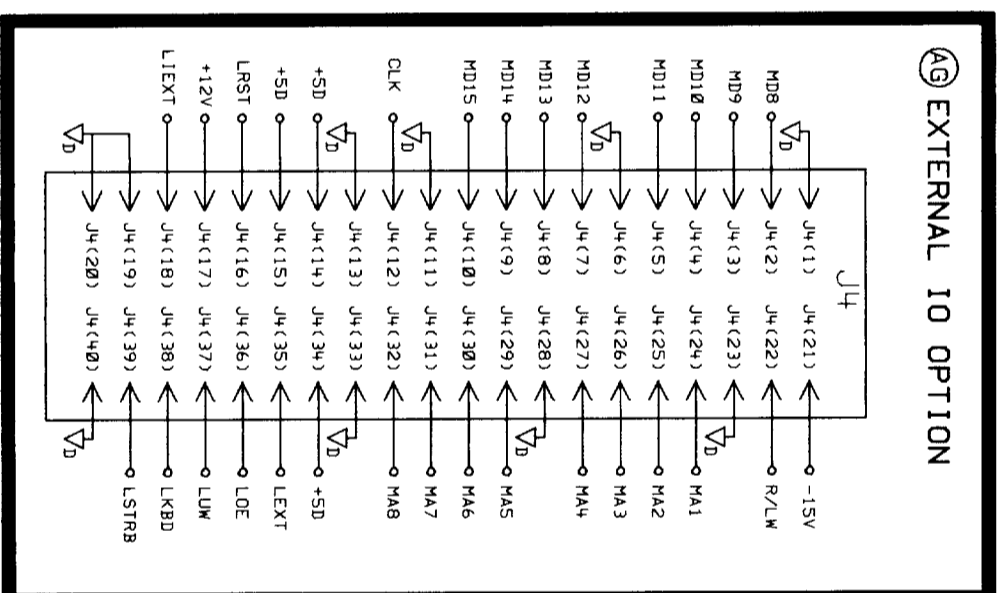
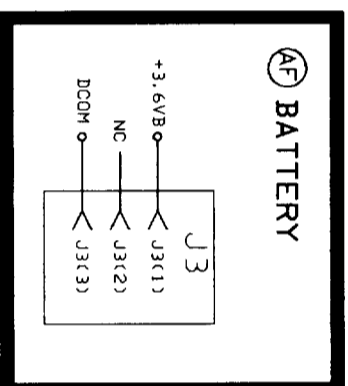
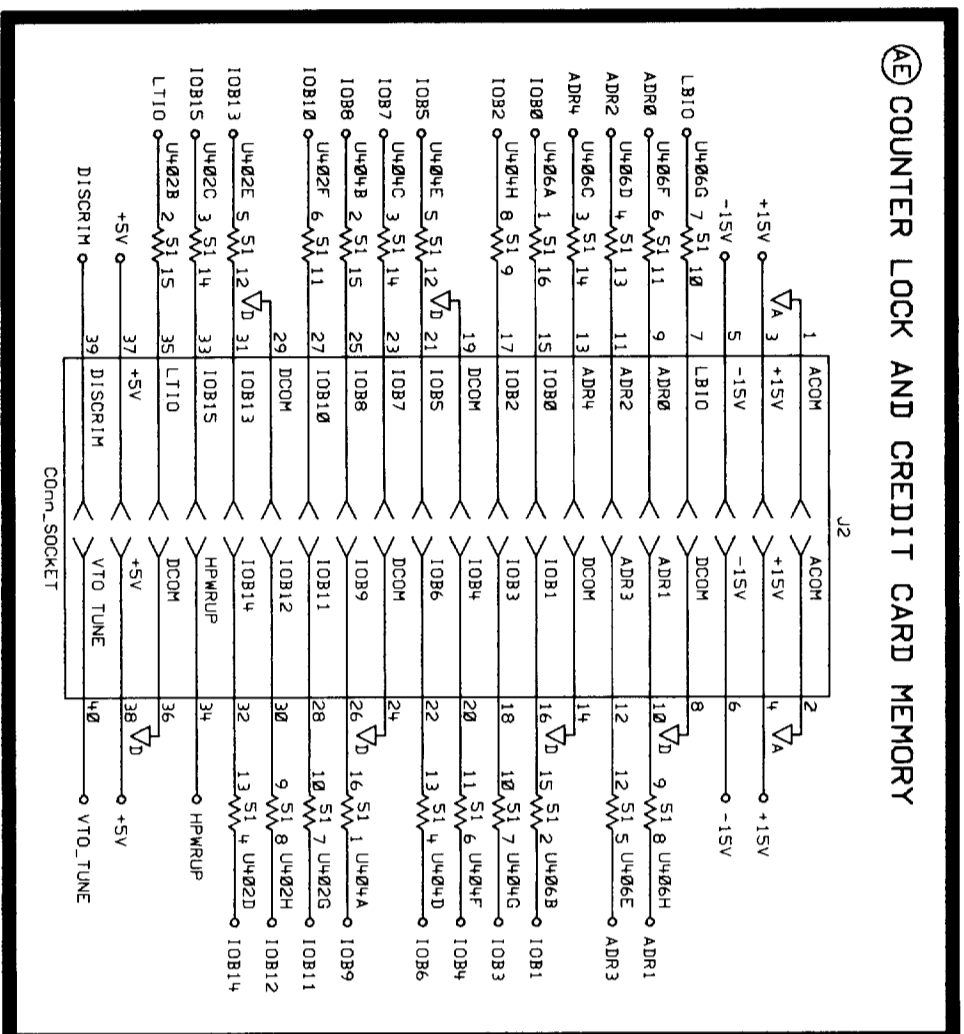
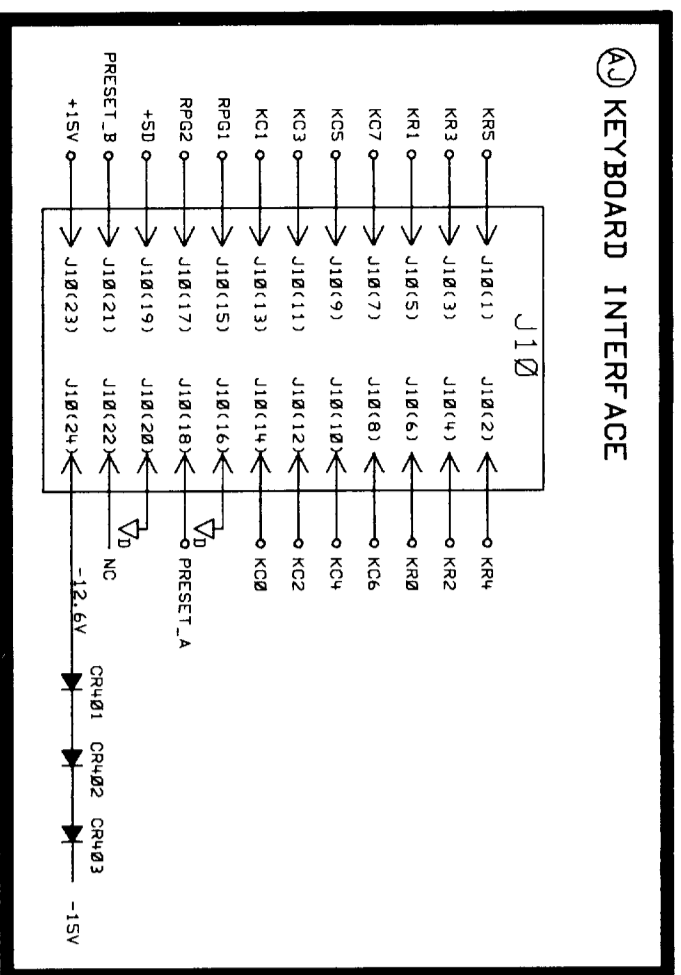
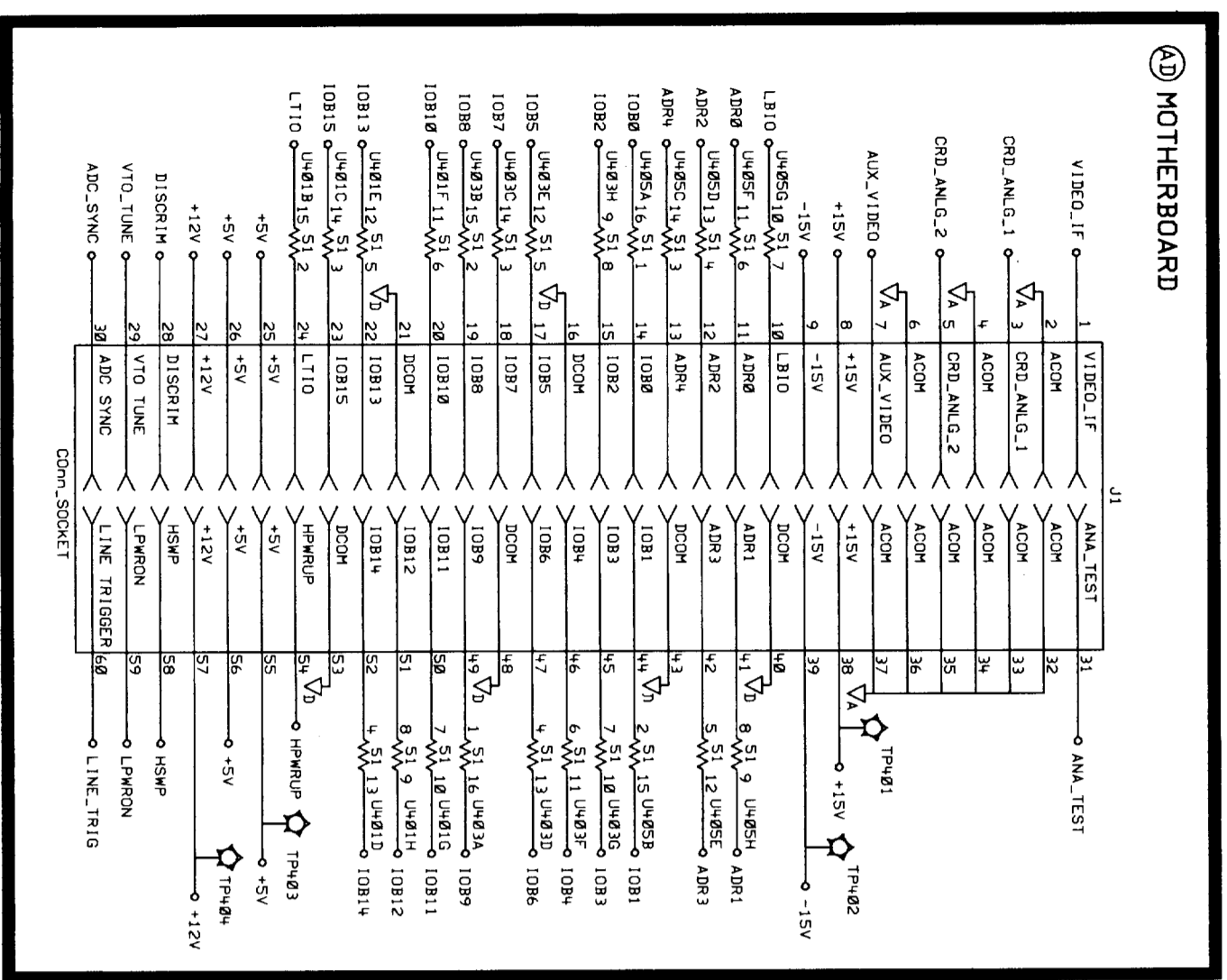

MINI-KONIC	SHEET		
	1	2	3
AD, SYNC	H	S	U
ANA TEST	E, F	P, Q	AD
CLK, VIDEO	J, K	R, S	AD
CONTR	L, M	T, V	AD
DATA	N	W	AD
ENVELOPE	O	X	AD
EXPAND	P	Y	AD
FEED	Q	Z	AD
FORM	R	AA	AD
FRONT	S	AB	AD
HEIGHT	T	AC	AD
INITIAL	U	AD	AD
LINE	V	AD	AD
LOAD	W	AD	AD
MARK	X	AD	AD
PRINT	Y	AD	AD
REVERSE	Z	AD	AD
START	AA	AD	AD
STOP	AB	AD	AD
VIDEO	AC	AD	AD
VIDEO	AD	AD	AD

THIS DRAWING ALSO USED FOR THE FOLLOWING ASSEMBLIES:
 08590-60102 08590-60102 A
 08592-60068 08592-60068 A
 PART NO. MATERIAL LIST REMARKS
 TABLE 1